

BENSON TOWER CONDOMINIUM

A PORTION OF LOT 6, AND ALL OF LOT 7 & 8,
 BLOCK 243, "CITY OF PORTLAND"
 LOCATED IN THE NORTHEAST 1/4 OF SECTION 4
 TOWNSHIP 1 SOUTH, RANGE 1 EAST, WILLAMETTE MERIDIAN,
 CITY OF PORTLAND, MULTNOMAH COUNTY, OREGON
 SHEET 1 OF 23

APRIL 02, 2007

KURAHASHI & ASSOCIATES, INC.
 Civil Engineering • Water Resources
 Landscape Architecture • Planning
 4141 NE Oregon Street, Suite C
 Portland, Oregon 97208
 (503)944-6842 Fax: (503)944-9720

REFERENCES:
 PLATS OF RECORD, MULTNOMAH COUNTY
 "CITY OF PORTLAND"

SURVEYS OF RECORD, MULTNOMAH COUNTY:
 S1 19984
 S2 2004-09245456
 S3 23684
 S4 30740
 S5 37184

MULTNOMAH COUNTY DEED RECORD REFERENCES:
 D1 2004-090395 VESTING DEED
 D2 2004-090395 VESTING DEED
 D3 2004-09245456
 D4 2004-215521
 D5 2004-215522
 D6 2005-007334
 D7 2005-007334
 D8 98-208269
 D9 97-04072
 D10 98-208269
 D11 BOOK 198, PAGE 123

NARRATIVE:
 THE PURPOSE OF THIS SURVEY IS TO MONUMENT THE BOUNDARIES OF A PORTION OF LOT 6
 & ALL OF LOT 7 & 8, BLOCK 243 "CITY OF PORTLAND" AS DESCRIBED IN (01) AND TO
 CREATE A CONDOMINIUM PLAN.

THE BASIS OF BEARINGS IS HELD THE FOUND BRASS SCREWS AND 3/4" BRASS WASHERS
 STAMPED "PUMPHREY PLS 1677" AT THE NORTHEAST CORNER OF LOT 8 AND THE
 SOUTHEAST CORNER OF (01) SOUTH 28'00" WEST PER SURVEY NUMBER 58949,
 MULTNOMAH COUNTY SURVEY RECORDS.

BOUNDARY WAS ESTABLISHED BY HOLDING FOUND MONUMENTS PER SAID SURVEY NUMBER
 58949. THE ORIGINAL MONUMENTS WERE DESTROYED IN CONSTRUCTION AND WERE RESET AS
 SHOWN FROM PERPETUATED ORIGINAL CONTROL.

VERTICAL DATUM: CITY OF PORTLAND BENCHMARK NO. 25416, A 3.1" BRASS CISK IN TOP
 OF THE SOUTHWEST CORNER OF SW CLAY STREET AND SW 12TH AVENUE. THE ELEVATION
 IS 107.47 FEET, CITY OF PORTLAND DATUM.

NOTES:
 1. ALL ANGLES ARE 90° UNLESS NOTED OTHERWISE.
 2. ALL DIMENSIONS ARE PERPENDICULAR TO LINE UNLESS NOTED OTHERWISE.
 3. EASEMENTS OF RECORD FOR LOT 6, 7, 8, 9, 10, 11, 12, 13, 14, 15, 16, 17, 18, 19, 20, 21, 22, 23, 24, 25, 26, 27, 28, 29, 30, 31, 32, 33, 34, 35, 36, 37, 38, 39, 40, 41, 42, 43, 44, 45, 46, 47, 48, 49, 50, 51, 52, 53, 54, 55, 56, 57, 58, 59, 60, 61, 62, 63, 64, 65, 66, 67, 68, 69, 70, 71, 72, 73, 74, 75, 76, 77, 78, 79, 80, 81, 82, 83, 84, 85, 86, 87, 88, 89, 90, 91, 92, 93, 94, 95, 96, 97, 98, 99, 100, 101, 102, 103, 104, 105, 106, 107, 108, 109, 110, 111, 112, 113, 114, 115, 116, 117, 118, 119, 120, 121, 122, 123, 124, 125, 126, 127, 128, 129, 130, 131, 132, 133, 134, 135, 136, 137, 138, 139, 140, 141, 142, 143, 144, 145, 146, 147, 148, 149, 150, 151, 152, 153, 154, 155, 156, 157, 158, 159, 160, 161, 162, 163, 164, 165, 166, 167, 168, 169, 170, 171, 172, 173, 174, 175, 176, 177, 178, 179, 180, 181, 182, 183, 184, 185, 186, 187, 188, 189, 190, 191, 192, 193, 194, 195, 196, 197, 198, 199, 200, 201, 202, 203, 204, 205, 206, 207, 208, 209, 210, 211, 212, 213, 214, 215, 216, 217, 218, 219, 220, 221, 222, 223, 224, 225, 226, 227, 228, 229, 230, 231, 232, 233, 234, 235, 236, 237, 238, 239, 240, 241, 242, 243, 244, 245, 246, 247, 248, 249, 250, 251, 252, 253, 254, 255, 256, 257, 258, 259, 260, 261, 262, 263, 264, 265, 266, 267, 268, 269, 270, 271, 272, 273, 274, 275, 276, 277, 278, 279, 280, 281, 282, 283, 284, 285, 286, 287, 288, 289, 290, 291, 292, 293, 294, 295, 296, 297, 298, 299, 300, 301, 302, 303, 304, 305, 306, 307, 308, 309, 310, 311, 312, 313, 314, 315, 316, 317, 318, 319, 320, 321, 322, 323, 324, 325, 326, 327, 328, 329, 330, 331, 332, 333, 334, 335, 336, 337, 338, 339, 340, 341, 342, 343, 344, 345, 346, 347, 348, 349, 350, 351, 352, 353, 354, 355, 356, 357, 358, 359, 360, 361, 362, 363, 364, 365, 366, 367, 368, 369, 370, 371, 372, 373, 374, 375, 376, 377, 378, 379, 380, 381, 382, 383, 384, 385, 386, 387, 388, 389, 390, 391, 392, 393, 394, 395, 396, 397, 398, 399, 400, 401, 402, 403, 404, 405, 406, 407, 408, 409, 410, 411, 412, 413, 414, 415, 416, 417, 418, 419, 420, 421, 422, 423, 424, 425, 426, 427, 428, 429, 430, 431, 432, 433, 434, 435, 436, 437, 438, 439, 440, 441, 442, 443, 444, 445, 446, 447, 448, 449, 450, 451, 452, 453, 454, 455, 456, 457, 458, 459, 460, 461, 462, 463, 464, 465, 466, 467, 468, 469, 470, 471, 472, 473, 474, 475, 476, 477, 478, 479, 480, 481, 482, 483, 484, 485, 486, 487, 488, 489, 490, 491, 492, 493, 494, 495, 496, 497, 498, 499, 500, 501, 502, 503, 504, 505, 506, 507, 508, 509, 510, 511, 512, 513, 514, 515, 516, 517, 518, 519, 520, 521, 522, 523, 524, 525, 526, 527, 528, 529, 530, 531, 532, 533, 534, 535, 536, 537, 538, 539, 540, 541, 542, 543, 544, 545, 546, 547, 548, 549, 550, 551, 552, 553, 554, 555, 556, 557, 558, 559, 560, 561, 562, 563, 564, 565, 566, 567, 568, 569, 570, 571, 572, 573, 574, 575, 576, 577, 578, 579, 580, 581, 582, 583, 584, 585, 586, 587, 588, 589, 590, 591, 592, 593, 594, 595, 596, 597, 598, 599, 600, 601, 602, 603, 604, 605, 606, 607, 608, 609, 610, 611, 612, 613, 614, 615, 616, 617, 618, 619, 620, 621, 622, 623, 624, 625, 626, 627, 628, 629, 630, 631, 632, 633, 634, 635, 636, 637, 638, 639, 640, 641, 642, 643, 644, 645, 646, 647, 648, 649, 650, 651, 652, 653, 654, 655, 656, 657, 658, 659, 660, 661, 662, 663, 664, 665, 666, 667, 668, 669, 670, 671, 672, 673, 674, 675, 676, 677, 678, 679, 680, 681, 682, 683, 684, 685, 686, 687, 688, 689, 690, 691, 692, 693, 694, 695, 696, 697, 698, 699, 700, 701, 702, 703, 704, 705, 706, 707, 708, 709, 710, 711, 712, 713, 714, 715, 716, 717, 718, 719, 720, 721, 722, 723, 724, 725, 726, 727, 728, 729, 730, 731, 732, 733, 734, 735, 736, 737, 738, 739, 740, 741, 742, 743, 744, 745, 746, 747, 748, 749, 750, 751, 752, 753, 754, 755, 756, 757, 758, 759, 760, 761, 762, 763, 764, 765, 766, 767, 768, 769, 770, 771, 772, 773, 774, 775, 776, 777, 778, 779, 780, 781, 782, 783, 784, 785, 786, 787, 788, 789, 790, 791, 792, 793, 794, 795, 796, 797, 798, 799, 800, 801, 802, 803, 804, 805, 806, 807, 808, 809, 810, 811, 812, 813, 814, 815, 816, 817, 818, 819, 820, 821, 822, 823, 824, 825, 826, 827, 828, 829, 830, 831, 832, 833, 834, 835, 836, 837, 838, 839, 840, 841, 842, 843, 844, 845, 846, 847, 848, 849, 850, 851, 852, 853, 854, 855, 856, 857, 858, 859, 860, 861, 862, 863, 864, 865, 866, 867, 868, 869, 870, 871, 872, 873, 874, 875, 876, 877, 878, 879, 880, 881, 882, 883, 884, 885, 886, 887, 888, 889, 890, 891, 892, 893, 894, 895, 896, 897, 898, 899, 900, 901, 902, 903, 904, 905, 906, 907, 908, 909, 910, 911, 912, 913, 914, 915, 916, 917, 918, 919, 920, 921, 922, 923, 924, 925, 926, 927, 928, 929, 930, 931, 932, 933, 934, 935, 936, 937, 938, 939, 940, 941, 942, 943, 944, 945, 946, 947, 948, 949, 950, 951, 952, 953, 954, 955, 956, 957, 958, 959, 960, 961, 962, 963, 964, 965, 966, 967, 968, 969, 970, 971, 972, 973, 974, 975, 976, 977, 978, 979, 980, 981, 982, 983, 984, 985, 986, 987, 988, 989, 990, 991, 992, 993, 994, 995, 996, 997, 998, 999, 1000, 1001, 1002, 1003, 1004, 1005, 1006, 1007, 1008, 1009, 1010, 1011, 1012, 1013, 1014, 1015, 1016, 1017, 1018, 1019, 1020, 1021, 1022, 1023, 1024, 1025, 1026, 1027, 1028, 1029, 1030, 1031, 1032, 1033, 1034, 1035, 1036, 1037, 1038, 1039, 1040, 1041, 1042, 1043, 1044, 1045, 1046, 1047, 1048, 1049, 1050, 1051, 1052, 1053, 1054, 1055, 1056, 1057, 1058, 1059, 1060, 1061, 1062, 1063, 1064, 1065, 1066, 1067, 1068, 1069, 1070, 1071, 1072, 1073, 1074, 1075, 1076, 1077, 1078, 1079, 1080, 1081, 1082, 1083, 1084, 1085, 1086, 1087, 1088, 1089, 1090, 1091, 1092, 1093, 1094, 1095, 1096, 1097, 1098, 1099, 1100, 1101, 1102, 1103, 1104, 1105, 1106, 1107, 1108, 1109, 1110, 1111, 1112, 1113, 1114, 1115, 1116, 1117, 1118, 1119, 1120, 1121, 1122, 1123, 1124, 1125, 1126, 1127, 1128, 1129, 1130, 1131, 1132, 1133, 1134, 1135, 1136, 1137, 1138, 1139, 1140, 1141, 1142, 1143, 1144, 1145, 1146, 1147, 1148, 1149, 1150, 1151, 1152, 1153, 1154, 1155, 1156, 1157, 1158, 1159, 1160, 1161, 1162, 1163, 1164, 1165, 1166, 1167, 1168, 1169, 1170, 1171, 1172, 1173, 1174, 1175, 1176, 1177, 1178, 1179, 1180, 1181, 1182, 1183, 1184, 1185, 1186, 1187, 1188, 1189, 1190, 1191, 1192, 1193, 1194, 1195, 1196, 1197, 1198, 1199, 1200, 1201, 1202, 1203, 1204, 1205, 1206, 1207, 1208, 1209, 1210, 1211, 1212, 1213, 1214, 1215, 1216, 1217, 1218, 1219, 1220, 1221, 1222, 1223, 1224, 1225, 1226, 1227, 1228, 1229, 1230, 1231, 1232, 1233, 1234, 1235, 1236, 1237, 1238, 1239, 1240, 1241, 1242, 1243, 1244, 1245, 1246, 1247, 1248, 1249, 1250, 1251, 1252, 1253, 1254, 1255, 1256, 1257, 1258, 1259, 1260, 1261, 1262, 1263, 1264, 1265, 1266, 1267, 1268, 1269, 1270, 1271, 1272, 1273, 1274, 1275, 1276, 1277, 1278, 1279, 1280, 1281, 1282, 1283, 1284, 1285, 1286, 1287, 1288, 1289, 1290, 1291, 1292, 1293, 1294, 1295, 1296, 1297, 1298, 1299, 1300, 1301, 1302, 1303, 1304, 1305, 1306, 1307, 1308, 1309, 1310, 1311, 1312, 1313, 1314, 1315, 1316, 1317, 1318, 1319, 1320, 1321, 1322, 1323, 1324, 1325, 1326, 1327, 1328, 1329, 1330, 1331, 1332, 1333, 1334, 1335, 1336, 1337, 1338, 1339, 1340, 1341, 1342, 1343, 1344, 1345, 1346, 1347, 1348, 1349, 1350, 1351, 1352, 1353, 1354, 1355, 1356, 1357, 1358, 1359, 1360, 1361, 1362, 1363, 1364, 1365, 1366, 1367, 1368, 1369, 1370, 1371, 1372, 1373, 1374, 1375, 1376, 1377, 1378, 1379, 1380, 1381, 1382, 1383, 1384, 1385, 1386, 1387, 1388, 1389, 1390, 1391, 1392, 1393, 1394, 1395, 1396, 1397, 1398, 1399, 1400, 1401, 1402, 1403, 1404, 1405, 1406, 1407, 1408, 1409, 1410, 1411, 1412, 1413, 1414, 1415, 1416, 1417, 1418, 1419, 1420, 1421, 1422, 1423, 1424, 1425, 1426, 1427, 1428, 1429, 1430, 1431, 1432, 1433, 1434, 1435, 1436, 1437, 1438, 1439, 1440, 1441, 1442, 1443, 1444, 1445, 1446, 1447, 1448, 1449, 1450, 1451, 1452, 1453, 1454, 1455, 1456, 1457, 1458, 1459, 1460, 1461, 1462, 1463, 1464, 1465, 1466, 1467, 1468, 1469, 1470, 1471, 1472, 1473, 1474, 1475, 1476, 1477, 1478, 1479, 1480, 1481, 1482, 1483, 1484, 1485, 1486, 1487, 1488, 1489, 1490, 1491, 1492, 1493, 1494, 1495, 1496, 1497, 1498, 1499, 1500, 1501, 1502, 1503, 1504, 1505, 1506, 1507, 1508, 1509, 1510, 1511, 1512, 1513, 1514, 1515, 1516, 1517, 1518, 1519, 1520, 1521, 1522, 1523, 1524, 1525, 1526, 1527, 1528, 1529, 1530, 1531, 1532, 1533, 1534, 1535, 1536, 1537, 1538, 1539, 1540, 1541, 1542, 1543, 1544, 1545, 1546, 1547, 1548, 1549, 1550, 1551, 1552, 1553, 1554, 1555, 1556, 1557, 1558, 1559, 1560, 1561, 1562, 1563, 1564, 1565, 1566, 1567, 1568, 1569, 1570, 1571, 1572, 1573, 1574, 1575, 1576, 1577, 1578, 1579, 1580, 1581, 1582, 1583, 1584, 1585, 1586, 1587, 1588, 1589, 1590, 1591, 1592, 1593, 1594, 1595, 1596, 1597, 1598, 1599, 1600, 1601, 1602, 1603, 1604, 1605, 1606, 1607, 1608, 1609, 1610, 1611, 1612, 1613, 1614, 1615, 1616, 1617, 1618, 1619, 1620, 1621, 1622, 1623, 1624, 1625, 1626, 1627, 1628, 1629, 1630, 1631, 1632, 1633, 1634, 1635, 1636, 1637, 1638, 1639, 1640, 1641, 1642, 1643, 1644, 1645, 1646, 1647, 1648, 1649, 1650, 1651, 1652, 1653, 1654, 1655, 1656, 1657, 1658, 1659, 1660, 1661, 1662, 1663, 1664, 1665, 1666, 1667, 1668, 1669, 1670, 1671, 1672, 1673, 1674, 1675, 1676, 1677, 1678, 1679, 1680, 1681, 1682, 1683, 1684, 1685, 1686, 1687, 1688, 1689, 1690, 1691, 1692, 1693, 1694, 1695, 1696, 1697, 1698, 1699, 1700, 1701, 1702, 1703, 1704, 1705, 1706, 1707, 1708, 1709, 1710, 1711, 1712, 1713, 1714, 1715, 1716, 1717, 1718, 1719, 1720, 1721, 1722, 1723, 1724, 1725, 1726, 1727, 1728, 1729, 1730, 1731, 1732, 1733, 1734, 1735, 1736, 1737, 1738, 1739, 1740, 1741, 1742, 1743, 1744, 1745, 1746, 1747, 1748, 1749, 1750, 1751, 1752, 1753, 1754, 1755, 1756, 1757, 1758, 1759, 1760, 1761, 1762, 1763, 1764, 1765, 1766, 1767, 1768, 1769, 1770, 1771, 1772, 1773, 1774, 1775, 1776, 1777, 1778, 1779, 1780, 1781, 1782, 1783, 1784, 1785, 1786, 1787, 1788, 1789, 1790, 1791, 1792, 1793, 1794, 1795, 1796, 1797, 1798, 1799, 1800, 1801, 1802, 1803, 1804, 1805, 1806, 1807, 1808, 1809, 1810, 1811, 1812, 1813, 1814, 1815, 1816, 1817, 1818, 1819, 1820, 1821, 1822, 1823, 1824, 1825, 1826, 1827, 1828, 1829, 1830, 1831, 1832, 1833, 1834, 1835, 1836, 1837, 1838, 1839, 1840, 1841, 1842, 1843, 1844, 1845, 1846, 1847, 1848, 1849, 1850, 1851, 1852, 1853, 1854, 1855, 1856, 1857, 1858, 1859, 1860, 1861, 1862, 1863, 1864, 1865, 1866, 1867, 1868, 1869, 1870, 1871, 1872, 1873, 1874, 1875, 1876, 1877, 1878, 1879, 1880, 1881, 1882, 1883, 1884, 1885, 1886, 1887, 1888, 1889, 1890, 1891, 1892, 1893, 1894, 1895, 1896, 1897, 1898, 1899, 1900, 1901, 1902, 1903, 1904, 1905, 1906, 1907, 1908, 1909, 1910, 1911, 1912, 1913, 1914, 1915, 1916, 1917, 1918, 1919, 1920, 1921, 1922, 1923, 1924, 1925, 1926, 1927, 1928, 1929, 1930, 1931, 1932, 1933, 1934, 1935, 1936, 1937, 1938, 1939, 1940, 1941, 1942, 1943, 1944, 1945, 1946, 1947, 1948, 1949, 1950, 1951, 1952, 1953, 1954, 1955, 1956, 1957, 1958, 1959, 1960, 1961, 1962, 1963, 1964, 1965, 1966, 1967, 1968, 1969, 1970, 1971, 1972, 1973, 1974, 1975, 1976, 1977, 1978, 1979, 1980, 1981, 1982, 1983, 1984, 1985, 1986, 1987, 1988, 1989, 1990, 1991, 1992, 1993, 1994, 1995, 1996, 1997, 1998, 1999, 2000, 2001, 2002, 2003, 2004, 200

BENSON TOWER CONDOMINIUM
 A PORTION OF LOT 6, AND ALL OF LOT 7 & 8,
 BLOCK 243, "CITY OF PORTLAND"
 LOCATED IN THE NORTHEAST 1/4 OF SECTION 4
 TOWNSHIP 1 SOUTH, RANGE 1 EAST
 WILLAMETTE MERIDIAN, CITY OF PORTLAND
 MULTNOMAH COUNTY, OREGON
 SHEET 3 OF 23

APRIL 02, 2007

KURAHASHI & ASSOCIATES, INC.
 Civil Engineering • Water Resources
 Landscape Architecture • Planning
 Environmental • Surveying
 4750 SW Third Street, Suite C
 Beaverton, OR 97005
 (503)844-6842 Fax: (503)844-9721

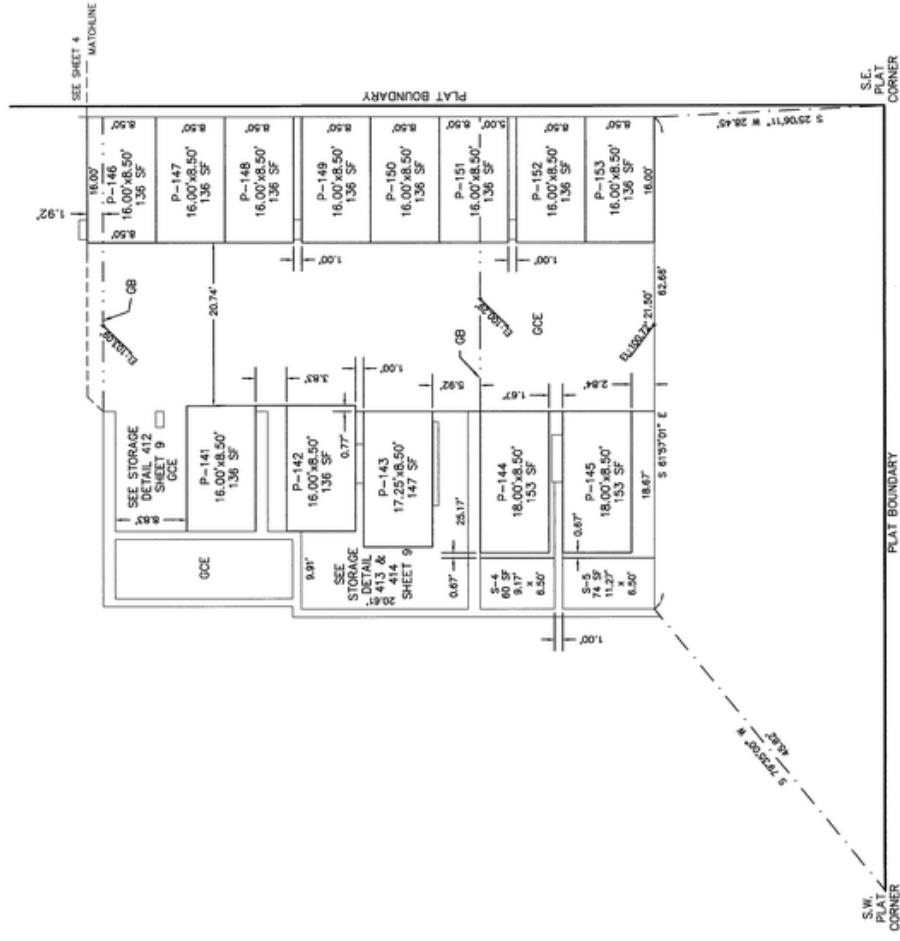

LEGEND

- SF DENOTES SQUARE FEET
- EL DENOTES FINISH FLOOR ELEVATION
- GCE DENOTES GENERAL COMMON ELEMENT
- GB DENOTES SLAB GRADE BREAK
- P DENOTES PARKING UNIT
- CB DENOTES SLAB GRADE BREAK

NOTES:

1. ALL ANGLES ARE 90° UNLESS NOTED OTHERWISE.
2. ALL DIMENSIONS ARE AS SHOWN UNLESS NOTED OTHERWISE.
3. EXCEPT AS OTHERWISE INDICATED, THE UPPER BOUNDARY OF PARKING AND STORAGE UNITS VERTICAL HEIGHT IS 7.00 FEET ABOVE THE FLOOR ELEVATIONS.

DATE 06-21-07
 REGISTERED PROFESSIONAL LAND SURVEYOR
 OREGON
 TIMOTHY H. ALDREDG
 53325
 EXPIRES 12-31-07

HEREBY CERTIFY THIS TO BE A TRUE AND CORRECT COPY OF THE ORIGINAL PLAT.
 THIS SURVEY WAS PREPARED USING THE FOLLOWING INSTRUMENTS: PRODUCT NO. 516424 ON POLYESTER FILM



**PARKING LEVEL 4B
 PLAN**

SW CLAY STREET

60' RIGHT OF WAY

BENSON TOWER CONDOMINIUM

A PORTION OF LOT 6, AND ALL OF LOT 7 & 8,
BLOCK 243, "CITY OF PORTLAND"
LOCATED IN THE NORTHEAST 1/4 OF SECTION 4
TOWNSHIP 1 SOUTH, RANGE 1 EAST
WILLAMETTE MERIDIAN, CITY OF PORTLAND
MULTNOMAH COUNTY, OREGON
SHEET 4 OF 23

APRIL 02, 2007

SEE SHEET 5
SEE SHEET 3

KURAHASHI & ASSOCIATES, INC.
Civil Engineering • Water Resources
Landscape Architecture • Planning
Environmental • Surveying
4470 SW Hall Street, Suite C
Portland, Oregon 97207
(503)444-8842 Fax: (503)444-9731

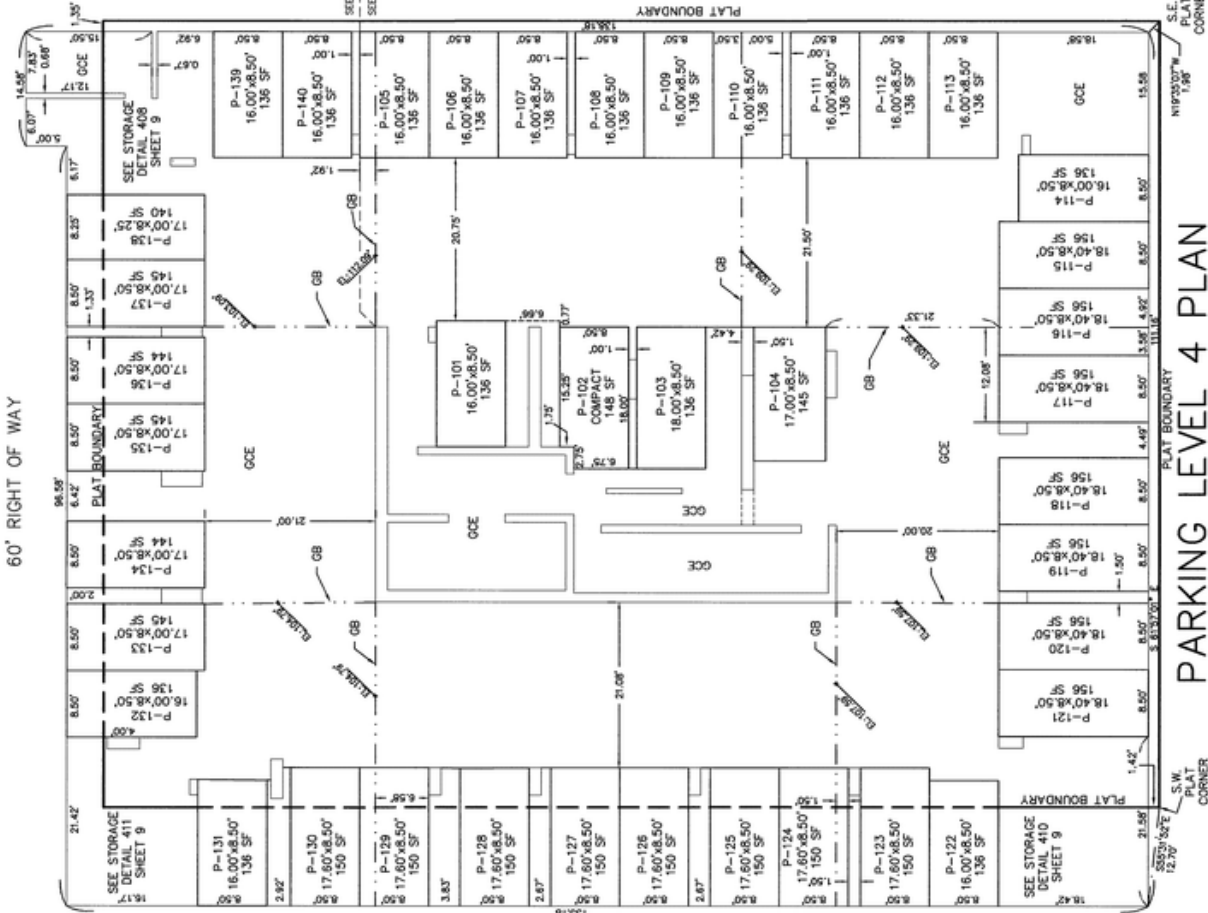

SW 11TH AVENUE
80' RIGHT OF WAY

LEGEND

- SF DENOTES SQUARE FEET
- EL DENOTES FINISH FLOOR ELEVATION
- CCE DENOTES GENERAL COMMON ELEMENT
- SU DENOTES STORAGE UNIT
- CA DENOTES COMMON AREA
- GB DENOTES SLAB GRADE BREAK

NOTES:

1. ALL ANGLES ARE 90° UNLESS NOTED OTHERWISE.
2. ALL DIMENSIONS ARE PERPENDICULAR UNLESS NOTED OTHERWISE.
3. PLAT LINES ARE SHOWN FOR SETBACKS, EASEMENTS AND STORAGE UNITS. VERTICAL HEIGHT IS 7.00 FEET ABOVE THE FLOOR ELEVATIONS.



SCALE: 1"=10'

DATE: 06-21-07
REGISTERED
PROFESSIONAL
LAND SURVEYOR
OREGON
JANUARY 14, 2003
MONTGOMERY LUDWIG
OCE 88342
EXPIRES 12-31-07

I HEREBY CERTIFY THIS TO BE A TRUE AND EXACT COPY OF THE ORIGINAL PLAN.

THIS SURVEY WAS PREPARED USING HEWLETT-PACKARD 9000 SERIES TOTAL STATION ON OCE 88342 POLYESTER FILM

PARKING LEVEL 4 PLAN

S.W. PLAT CORNER
S.E. PLAT CORNER

SW CLAY STREET

60' RIGHT OF WAY

BENSON TOWER CONDOMINIUM
 1.35' A PORTION OF LOT 6, AND ALL OF LOT 7 & 8,
 BLOCK 243, "CITY OF PORTLAND"
 LOCATED IN THE NORTHEAST 1/4 OF SECTION 4
 TOWNSHIP 1 SOUTH, RANGE 1 EAST
 WILLAMETTE MERIDIAN, CITY OF PORTLAND
 MULTNOMAH COUNTY, OREGON
 SHEET 5 OF 23

APRIL 02, 2007

SEE SHEET 6
 SEE SHEET 4

KURAHASHI & ASSOCIATES, INC.
 Civil Engineering • Water Resources
 Surveying • Planning
 Environmental • Surveying
 4470 SW Hall Blvd., Suite C
 Beaverton, Oregon 97005
 (503)944-6642 fax: (503)944-9701

SW 11TH AVENUE
 80' RIGHT OF WAY

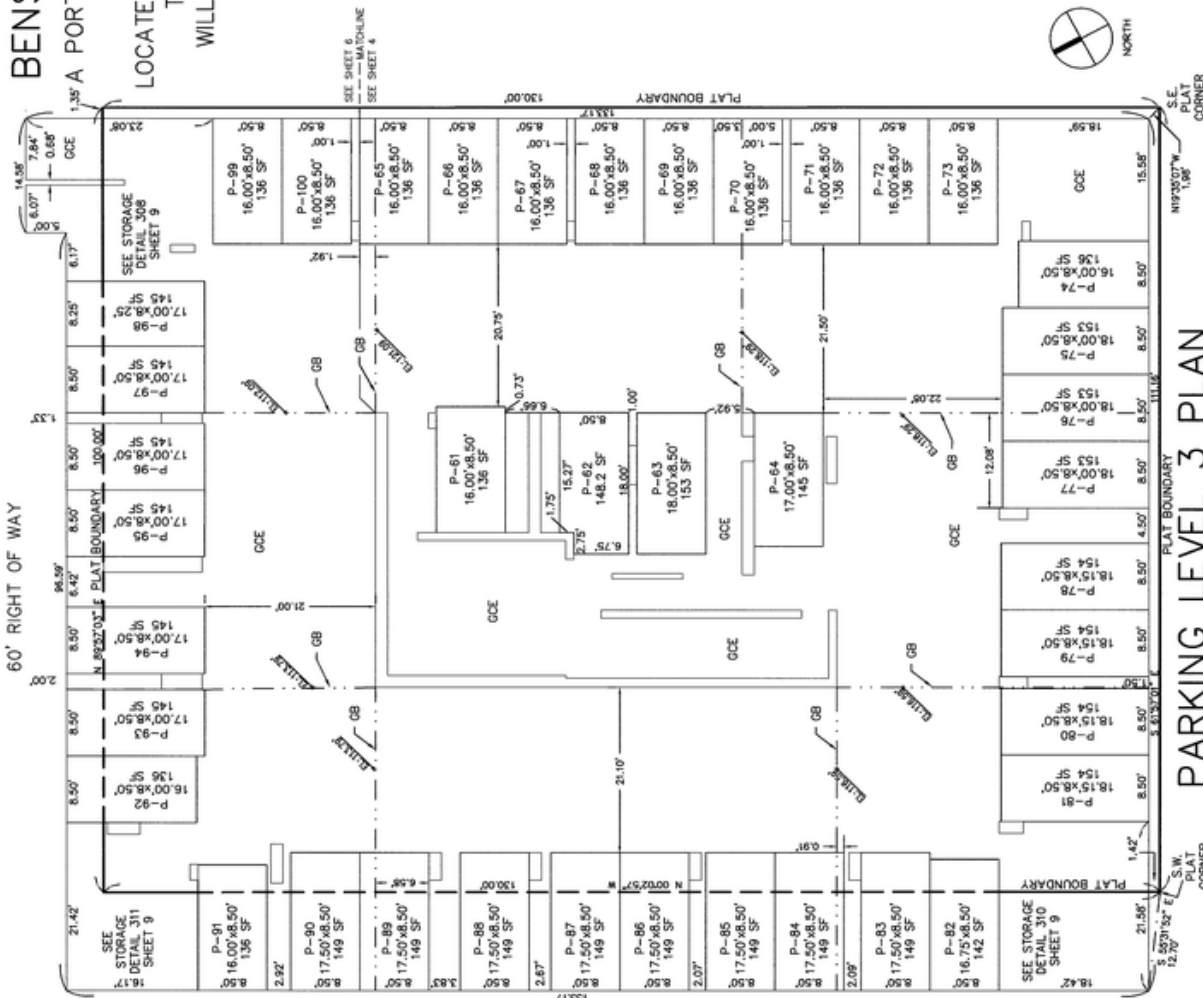

LEGEND

- SF DENOTES SQUARE FEET
- EL DENOTES FINISH FLOOR ELEVATION
- CE DENOTES GENERAL COMMON ELEMENT
- P- DENOTES STORAGE UNIT
- GB DENOTES STAIR GRADE BREAK
- OB DENOTES SUB GRADE BREAK

NOTES:

1. ALL ANGLES ARE 90° UNLESS NOTED OTHERWISE.
2. ALL DIMENSIONS ARE DECIMALS UNLESS NOTED OTHERWISE.
3. ALL DIMENSIONS ARE TO THE CENTERLINE OF WALLS UNLESS NOTED OTHERWISE.
4. UNITS VERTICAL HEIGHT IS 7.00 FEET ABOVE THE FLOOR ELEVATIONS.

DATE: 06-21-07
 REGISTERED
 PROFESSIONAL
 LAND SURVEYOR
 Tracy H. Kelley
 OREGON
 JANUARY 14, 2003
 HENLEY-PARKADO
 PRODUCT NO. 51640A ON
 OCE FILM
 PLS 031001 FLM
 EXPIRES 12-31-07

I HEREBY CERTIFY THIS TO
 BE A TRUE AND CORRECT
 COPY OF THE ORIGINAL
 PLAN.

THIS SURVEY WAS
 MADE BY ME OR UNDER
 MY CLOSE PERSONAL
 SUPERVISION AND I AM
 A LICENSED SURVEYOR
 IN THE STATE OF OREGON.



PARKING LEVEL 3 PLAN

BENSON TOWER CONDOMINIUM
 A PORTION OF LOT 6, AND ALL OF LOT 7 & 8,
 BLOCK 243, "CITY OF PORTLAND"
 LOCATED IN THE NORTHEAST 1/4 OF SECTION 4
 TOWNSHIP 1 SOUTH, RANGE 1 EAST
 WILLAMETTE MERIDIAN, CITY OF PORTLAND
 MULTNOMAH COUNTY, OREGON
 SHEET 7 OF 23

APRIL 02, 2007

KURAHASHI & ASSOCIATES, INC.
 Civil Engineering • Water Resources
 Landscape Architecture • Planning
 Environmental • Surveying
 4470 SW Ball Blvd, Suite C
 Portland, Oregon 97207
 (503)944-6642 Fax: (503)944-9720

LEGEND

- SF DENOTES SQUARE FEET
- DL DENOTES FINISH FLOOR ELEVATION
- CE DENOTES ORIGINAL COMMON ELEMENT
- OB DENOTES ORIGINAL BOUNDARY
- P- DENOTES PARKING UNIT
- GB DENOTES SLAB GRADE BREAK

NOTES:

1. ALL ANGLES ARE 90° UNLESS NOTED OTHERWISE
2. ALL MEASUREMENTS ARE PERPENDICULAR UNLESS NOTED OTHERWISE
3. EXCEPT AS OTHERWISE INDICATED, THE UPPER BOUNDARY OF PARKING AND STORAGE UNITS VERTICAL HEIGHT IS 7.00 FEET ABOVE THE FLOOR ELEVATIONS.

DATE 06-21-07
 REGISTERED PROFESSIONAL LAND SURVEYOR
 TIMOTHY H. ALCOVER
 OREGON LICENSE NO. 3303
 EXPIRES 12-31-07

THIS SURVEY WAS CONDUCTED IN ACCORDANCE WITH THE HEMLETT-PADGUGO ACT, PRODUCT NO. 55580A, ON POLYESTER FILM

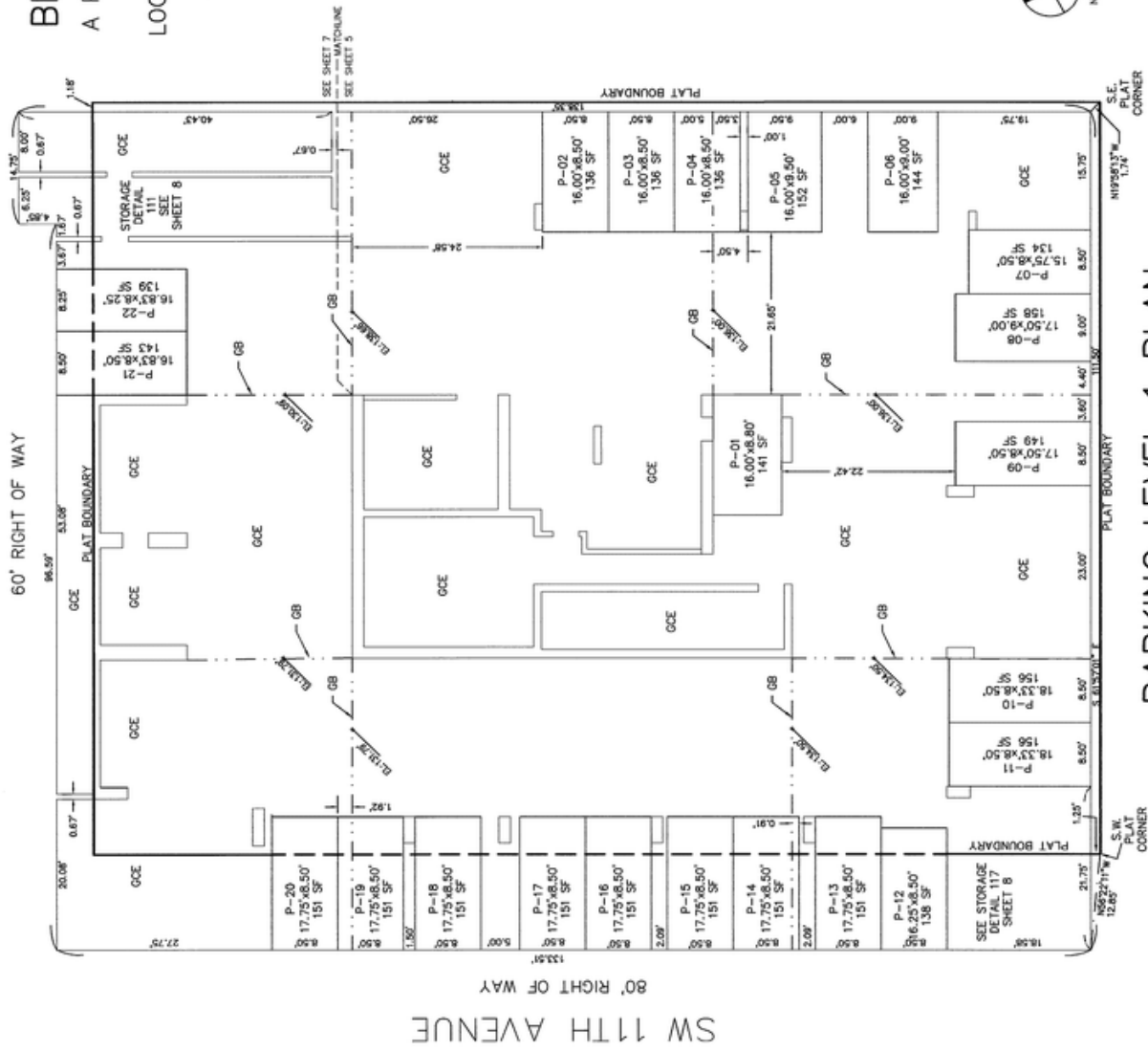

PARKING LEVEL 1 PLAN

BENSON TOWER CONDOMINIUM
 A PORTION OF LOT 6, AND ALL OF LOT 7 & 8,
 BLOCK 243, "CITY OF PORTLAND"
 LOCATED IN THE NORTHEAST 1/4 OF SECTION 4
 TOWNSHIP 1 SOUTH, RANGE 1 EAST
 WILLAMETTE MERIDIAN, CITY OF PORTLAND
 MULTNOMAH COUNTY, OREGON
 SHEET 8 OF 23

APRIL 02, 2007

LEGEND:

- GCE DENOTES GENERAL COMMON ELEMENT
- S- DENOTES STORAGE UNIT
- P- DENOTES PARKING UNIT

NOTES:

1. ALL ANGLES ARE 90° UNLESS NOTED OTHERWISE.
2. ALL DIMENSIONS ARE PERPENDICULAR UNLESS NOTED OTHERWISE.
3. EXCEPT AS OTHERWISE INDICATED, THE UPPER BOUNDARY OF PARKING AND STORAGE UNITS VERTICAL HEIGHT IS 7.00 FEET ABOVE THE FLOOR ELEVATION.
4. SEE SHEET 3 FOR UNITS 4 & 5.

KURAHASHI & ASSOCIATES, INC.
 Civil Engineering • Water Resource
 Landscape Architecture • Planning
 Environmental Stippling
 4470 SW 16th, Bldg. Suite C
 Beaverton, Oregon 97005
 (503)944-5842 Fax: (503)944-9731

I HEREBY CERTIFY THIS TO BE A TRUE AND EXACT COPY OF THE ORIGINAL PLAN.

THIS SURVEY WAS PREPARED USING THE FOLLOWING INSTRUMENTS:
 PRODUCT NO. 51640A ON POLYESTER FILM
 GCE M342

DATE: 06-21-07
 REGISTERED PROFESSIONAL LAND SURVEYOR
 Timothy A. Llovera
 EXPIRES 12-31-07



SCALE: 1"=5'

**PARKING LEVELS
 STORAGE DETAILS**

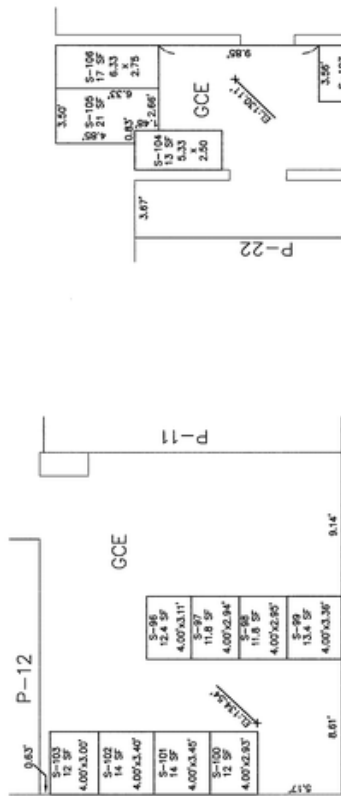

BENSON TOWER CONDOMINIUM
 A PORTION OF LOT 6, AND ALL OF LOT 7 & 8,
 BLOCK 243, "CITY OF PORTLAND"
 LOCATED IN THE NORTHEAST 1/4 OF SECTION 4
 TOWNSHIP 1 SOUTH, RANGE 1 EAST
 WILLAMETTE MERIDIAN, CITY OF PORTLAND
 MULTNOMAH COUNTY, OREGON
 SHEET 10 OF 23

S.W. 11TH AVENUE

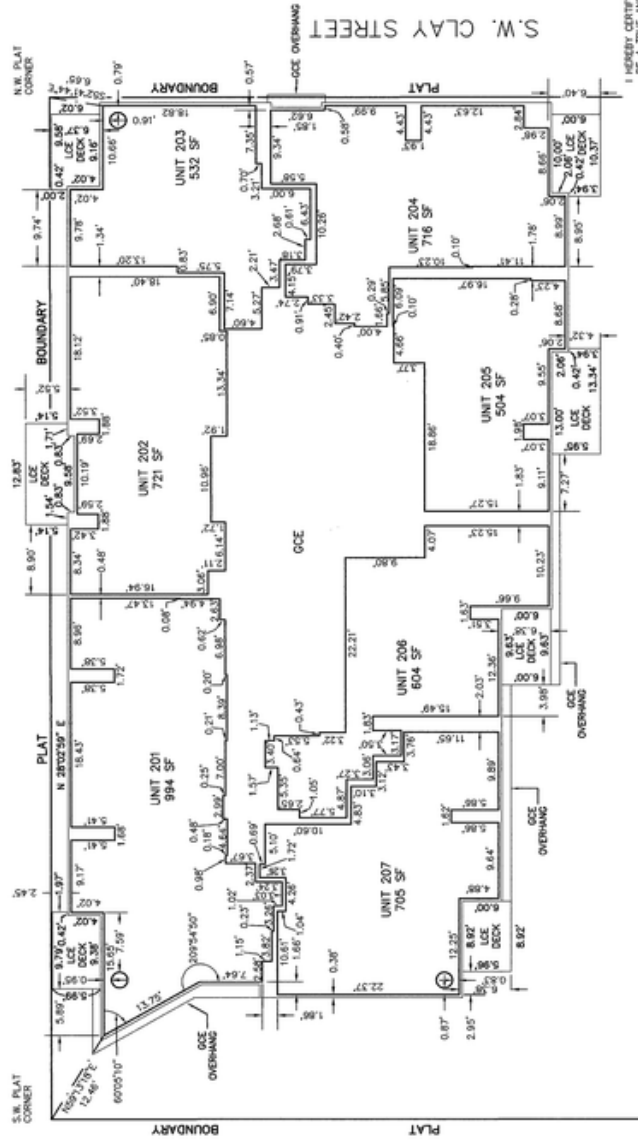

LEGEND
 GCE - DENOTES GENERAL COMMON ELEMENT
 LCE - DENOTES LIMITED COMMON ELEMENT
 SF - DENOTES SQUARE FEET

NOTES:
 1. ALL WALL ANGLES ARE 90° UNLESS NOTED OTHERWISE.
 2. ALL GENERAL COMMON ELEMENTS STRUCTURAL COLUMNS HAVE BEEN DEDUCTED FROM LIVING UNIT SQUARE FOOTAGES.

○
 TYPICAL GCE
 STRUCTURAL
 COLUMN
 2.00' DIAMETER
 3.14 SF

I HEREBY CERTIFY THIS TO BE A TRUE AND CORRECT COPY OF THE ORIGINAL PLAT.

THIS SURVEY WAS PREPARED BY ME OR UNDER MY CLOSE PERSONAL SUPERVISION AND I AM A LICENSED PROFESSIONAL LAND SURVEYOR IN THE STATE OF OREGON.
 PRODUCT NO. 51640A ON 10/25/2007
 DATE: 06-21-07

REGISTERED PROFESSIONAL LAND SURVEYOR
Timothy M. Allover
 OREGON
 JANUARY 14, 2003
 TIMOTHY M. ALLOVER
 EXPIRES 12-31-07



**FLOOR PLAN
 LEVEL 2**

KURAHASHI & ASSOCIATES, INC.
 Civil Engineering • Water Resources
 Landscape Architecture • Planning
 Environmental • Surveying
 4470 SW Hall Blvd., Suite C
 Portland, Oregon 97209
 (503)444-6642 Fax: (503)944-9721

BENSON TOWER CONDOMINIUM

A PORTION OF LOT 6, AND ALL OF LOT 7 & 8,
 BLOCK 243, "CITY OF PORTLAND"
 LOCATED IN THE NORTHEAST 1/4 OF SECTION 4
 TOWNSHIP 1 SOUTH, RANGE 1 EAST
 WILLAMETTE MERIDIAN, CITY OF PORTLAND
 MULTNOMAH COUNTY, OREGON
 SHEET 12 OF 23

APRIL 02, 2007

LEGEND

GCE - DENOTES GENERAL COMMON ELEMENT
 LCE - DENOTES LIMITED COMMON ELEMENT
 SF - DENOTES SQUARE FEET

NOTES:

1. ALL WALL ANGLES ARE 90° UNLESS NOTED OTHERWISE.
2. ALL GENERAL COMMON ELEMENTS STRUCTURAL COLUMNS HAVE BEEN DEDUCTED FROM LIVING UNIT SQUARE FOOTAGES.

○
 TYPICAL GCE
 STRUCTURAL
 COLUMN
 2.00' DIAMETER
 3.14 SF

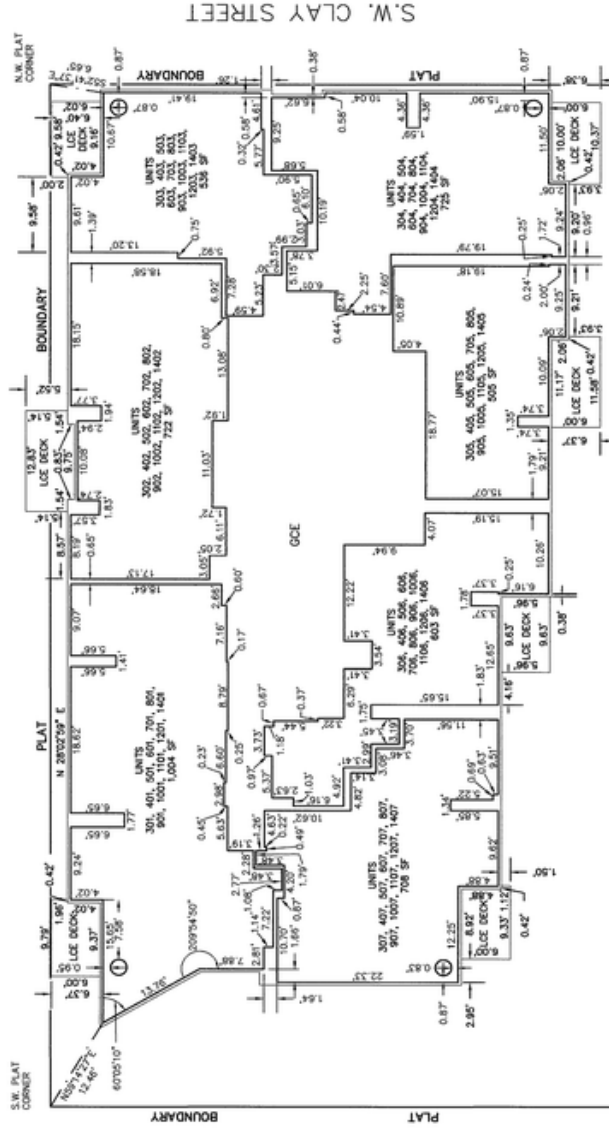

FLOOR PLAN (TYPICAL)
 LEVELS 3-14

I HEREBY CERTIFY THIS TO BE A TRUE AND EXACT COPY OF THE ORIGINAL PLAN.

THIS SURVEY WAS PREPARED USING METRETT-PACKARD SURVEYING INSTRUMENTS ON POLYESTER FILM

DATE: 06-21-07
 REGISTERED PROFESSIONAL LAND SURVEYOR
 OREGON
 Timothy A. Alford
 EXPIRES 12-31-07

KURAHASHI & ASSOCIATES, INC.
 Civil Engineering • Water Resources
 Landscape Architecture • Planning
 Environmental • Surveying
 4470 SW Hall Blvd., Suite C
 Portland, Oregon 97209
 (503)944-6662 Fax: (503)944-9721

BENSON TOWER CONDOMINIUM
 A PORTION OF LOT 6, AND ALL OF LOT 7 & 8,
 BLOCK 243, "CITY OF PORTLAND"
 LOCATED IN THE NORTHEAST 1/4 OF SECTION 4
 TOWNSHIP 1 SOUTH, RANGE 1 EAST
 WILLAMETTE MERIDIAN, CITY OF PORTLAND
 MULTNOMAH COUNTY, OREGON
 SHEET 14 OF 23

S.W. 11TH AVENUE

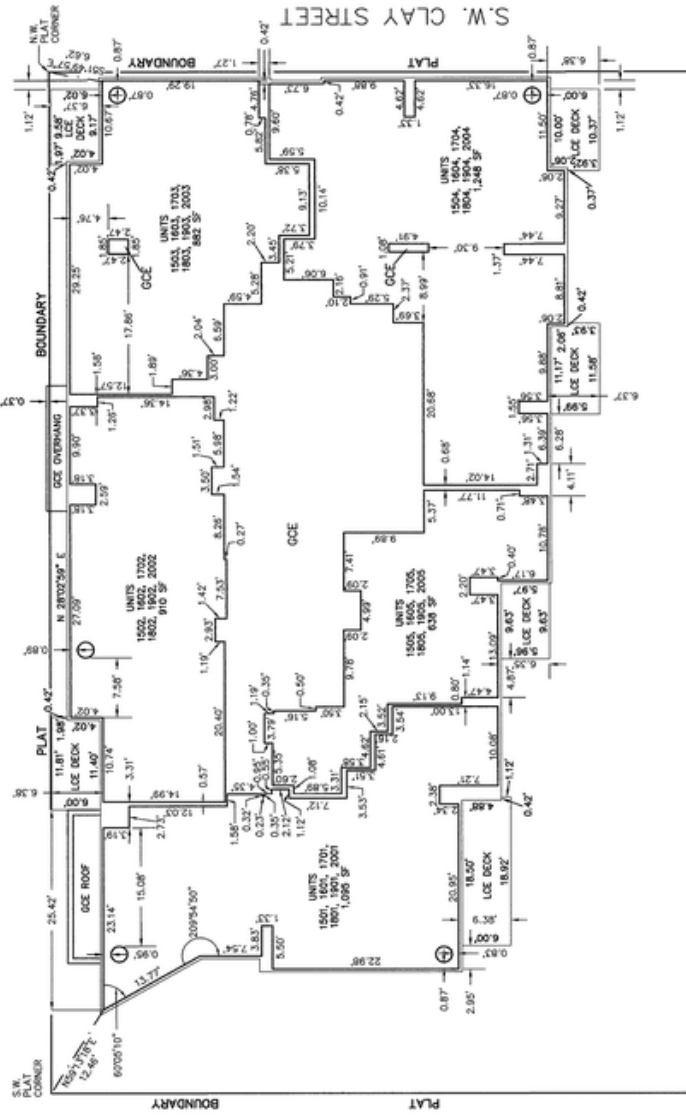

APRIL 02, 2007

LEGEND
 OCE - DENOTES GENERAL COMMON ELEMENT
 LOE - DENOTES LIMITED COMMON ELEMENT
 SF - DENOTES SQUARE FEET

NOTES:

1. ALL WALL ANGLES ARE 90° UNLESS NOTED OTHERWISE.
2. ALL GENERAL COMMON ELEMENTS STRUCTURAL COLUMNS HAVE BEEN DEDUCTED FROM LIVING UNIT SQUARE FOOTAGES.

○
 TYPICAL GCE
 STRUCTURAL
 COLUMN
 2.00' DIAMETER
 3.14 SF

I HEREBY CERTIFY THIS TO
 BE A TRUE AND CORRECT
 COPY OF THE ORIGINAL
 PLAT.

THIS SURVEY WAS
 PREPARED USING
 INSTRUMENT NO. 55544A ON
 PRODUCT NO. 55544A ON
 OCE 86342
 POLYESTER FILM



FLOOR PLAN (TYPICAL)
 LEVELS 15-20

DATE: 04-21-07
 REGISTERED
 PROFESSIONAL
 LAND SURVEYOR
 JAMES H. ALCOVER
 OREGON LICENSE NO. 3033
 TIMOTHY A. ALCOVER
 53835
 EXPIRES 12-31-07

KURAHASHI
& ASSOCIATES, INC.
 Civil Engineering • Water Resources
 Landscape Architecture • Planning
 Environmental • Surveying
 4470 SW Hall Blvd., Suite C
 Portland, Oregon 97209
 (503)944-6642 Fax: (503)944-9721

BENSON TOWER CONDOMINIUM
 A PORTION OF LOT 6, AND ALL OF LOT 7 & 8,
 BLOCK 243, "CITY OF PORTLAND"
 LOCATED IN THE NORTHEAST 1/4 OF SECTION 4
 TOWNSHIP 1 SOUTH, RANGE 1 EAST
 WILLAMETTE MERIDIAN, CITY OF PORTLAND
 MULTNOMAH COUNTY, OREGON
 SHEET 15 OF 23

APRIL 02, 2007

LEGEND

VM - DENOTES VERTICAL HEIGHT OF CEILINGS
 GCE - DENOTES COMMON ELEMENT
 LCE - DENOTES LIMITED COMMON ELEMENT

NOTES:

1. ALL WALL AND CEILING ANGLES ARE 90° UNLESS NOTED OTHERWISE.
2. SEE SHEET 2 FOR FLOOR ELEVATIONS.

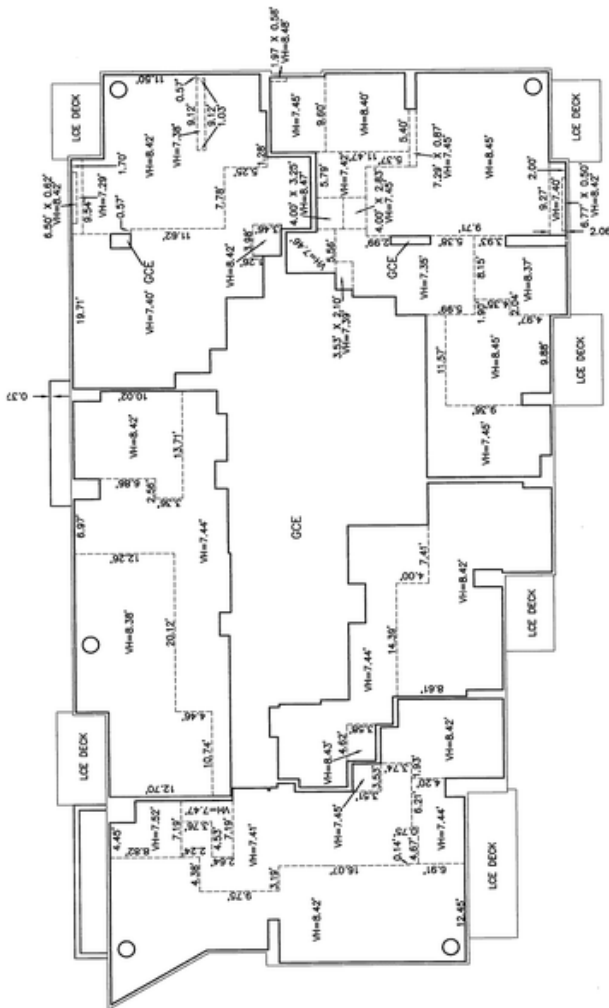

I HEREBY CERTIFY THIS TO BE A TRUE AND EXACT COPY OF THE ORIGINAL PLAN.

THE SURVEY WAS PREPARED USING THE FOLLOWING INSTRUMENTS: TOTAL STATION ON POLYESTER FILM

DATE: 06-21-07



CEILING PLAN (TYPICAL)
 LEVELS 15-20

KURAHASHI & ASSOCIATES, INC.
 Civil Engineering • Water Resources
 Environmental • Planning
 4470 SW Hall Blvd., Suite C
 Beaverton, Oregon 97005
 (503)644-6882 Fax: (503)644-9711

BENSON TOWER CONDOMINIUM
 A PORTION OF LOT 6, AND ALL OF LOT 7 & 8,
 BLOCK 243, "CITY OF PORTLAND"
 LOCATED IN THE NORTHEAST 1/4 OF SECTION 4
 TOWNSHIP 1 SOUTH, RANGE 1 EAST
 WILLAMETTE MERIDIAN, CITY OF PORTLAND
 MULTNOMAH COUNTY, OREGON
 SHEET 16 OF 23

S.W. 11TH AVENUE

APRIL 02, 2007

LEGEND
 GCE - DENOTES GENERAL COMMON ELEMENT
 LCE - DENOTES LIMITED COMMON ELEMENT
 SF - DENOTES SQUARE FEET

NOTES:

1. ALL WALL ANGLES ARE 90° UNLESS NOTED OTHERWISE.
2. WALLS ARE GENERAL COMMON ELEMENT AND MAY VARY IN THICKNESS DUE TO CONSTRUCTION.
3. ALL GENERAL COMMON ELEMENTS STRUCTURAL COLUMNS HAVE BEEN DERIVED FROM LIVING UNIT SQUARE FOOTAGES.

○
 TYPICAL GCE
 STRUCTURAL
 COLUMN
 2.00' DIAMETER
 3.14 SF

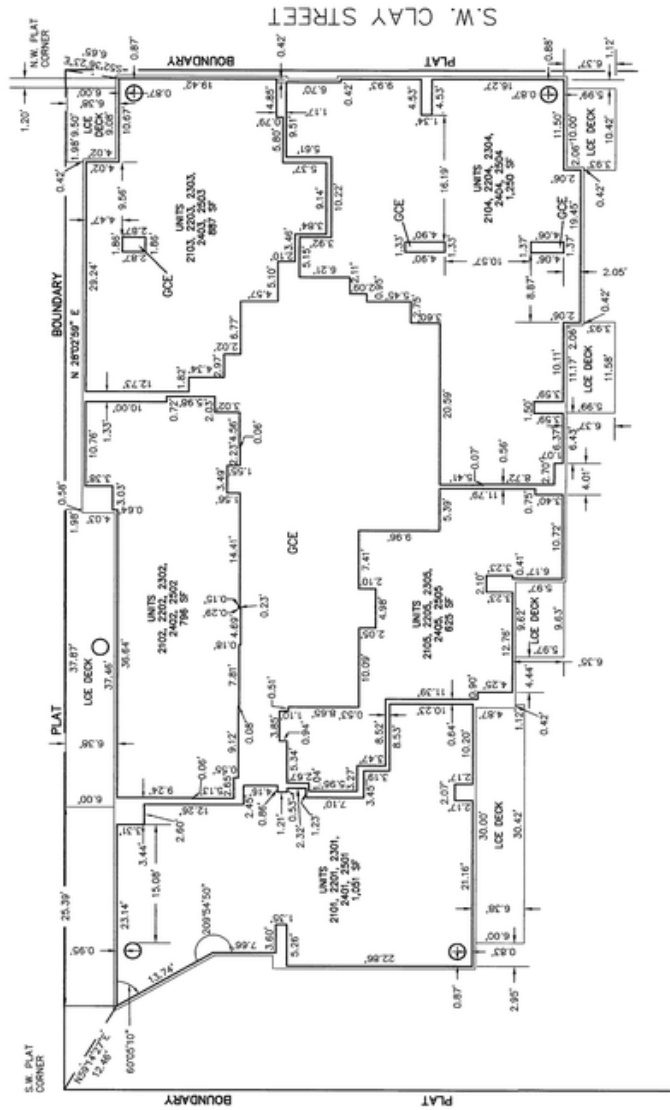

I HEREBY CERTIFY THIS TO BE A TRUE AND CORRECT COPY OF ORIGINAL

THIS SURVEY WAS PREPARED USING THE FOLLOWING INSTRUMENT PRODUCT NO. 514404 ON POLYESTER FILM



DATE: 06-21-07
 REGISTERED PROFESSIONAL LAND SURVEYOR
 TERRY N. ALCOVER
 OREGON LICENSE NO. 53850
 EXPIRES 12-31-07

FLOOR PLAN (TYPICAL)
 LEVELS 21-25

KURAHASHI & ASSOCIATES, INC.
 Civil Engineering • Water Resources
 Landscape Architecture • Planning
 Environmental • Surveying
 4470 SW Hall Blvd, Suite C
 Portland, Oregon 97209
 (503)944-9542 Fax: (503)944-9721

BENSON TOWER CONDOMINIUM
 A PORTION OF LOT 6, AND ALL OF LOT 7 & 8,
 BLOCK 243, "CITY OF PORTLAND"
 LOCATED IN THE NORTHEAST 1/4 OF SECTION 4
 TOWNSHIP 1 SOUTH, RANGE 1 EAST
 WILLAMETTE MERIDIAN, CITY OF PORTLAND
 MULTNOMAH COUNTY, OREGON
 SHEET 19 OF 23

APRIL 02, 2007

LEGEND

- GCE - DENOTES GENERAL COMMON ELEMENT
- LOE - DENOTES LIMITED COMMON ELEMENT
- SF - DENOTES SQUARE FEET

NOTES:

1. ALL WALL ANGLES ARE 90° UNLESS NOTED OTHERWISE.
2. ALL GENERAL COMMON ELEMENTS STRUCTURAL COLUMNS HAVE BEEN DEDUCTED FROM LIVING UNIT SQUARE FOOTAGES.

○
 TYPICAL GCE
 STRUCTURAL
 COLUMN
 2.00' DIAMETER
 3.14 SF

S.W. 11TH AVENUE

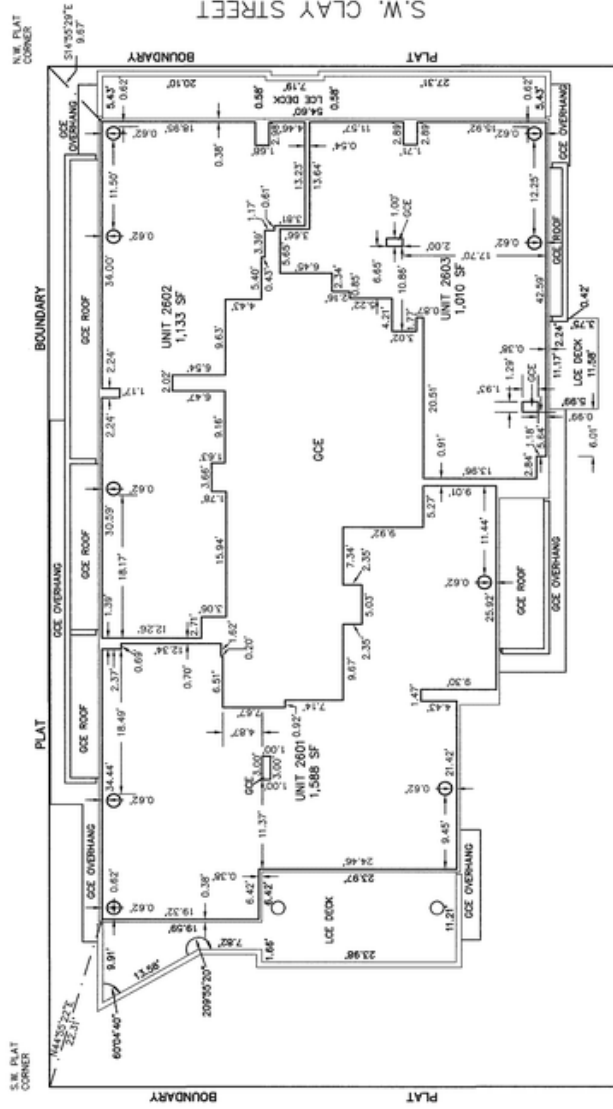

THIS SURVEY WAS
 PREPARED BY
 HERBIE GERRY, INC. IN
 ACCORDANCE WITH
 OREGON RULES AND
 REGULATIONS
 GOVERNING
 SURVEYING
 PRACTICE
 A TRUE AND CORRECT
 COPY OF THE ORIGINAL
 PLAT.

THIS SURVEY WAS
 PREPARED BY
 HERBIE GERRY, INC. IN
 ACCORDANCE WITH
 OREGON RULES AND
 REGULATIONS
 GOVERNING
 SURVEYING
 PRACTICE
 A TRUE AND CORRECT
 COPY OF THE ORIGINAL
 PLAT.



FLOOR PLAN
LEVEL 26

DATE: 06-21-07
 REGISTERED
 PROFESSIONAL
 LAND SURVEYOR
 T. GERRY, INC.
 OREGON
 JANUARY 14, 2003
 TIMOTHY M. ALCOVER
 LICENSE NO. 3382
 EXPIRES 12-31-07

KURAHASHI
& ASSOCIATES, INC.
 Civil Engineering • Water Resources
 Landscape Architecture • Planning
 Environmental • Surveying
 4470 SW Hall Blvd., Suite C
 Portland, Oregon 97207
 (503) 944-8832 Fax: (503) 944-8731

BENSON TOWER CONDOMINIUM
 A PORTION OF LOT 6, AND ALL OF LOT 7 & 8,
 BLOCK 243, "CITY OF PORTLAND"
 LOCATED IN THE NORTHEAST 1/4 OF SECTION 4
 TOWNSHIP 1 SOUTH, RANGE 1 EAST
 WILLAMETTE MERIDIAN, CITY OF PORTLAND
 MULTNOMAH COUNTY, OREGON
 SHEET 21 OF 23

APRIL 02, 2007

LEGEND

GCE - DENOTES GENERAL COMMON ELEMENT
 LCE - DENOTES LIMITED COMMON ELEMENT
 SF - DENOTES SQUARE FEET

NOTES:

1. ALL WALL ANGLES ARE 90° UNLESS NOTED OTHERWISE.
2. ALL GENERAL COMMON ELEMENTS STRUCTURAL COLUMNS HAVE BEEN DEDUCTED FROM LIVING UNIT SQUARE FOOTAGES.

○
 TYPICAL GCE
 STRUCTURAL
 COLUMN
 2.00' DIAMETER
 3.14 SF

S.W. 11TH AVENUE

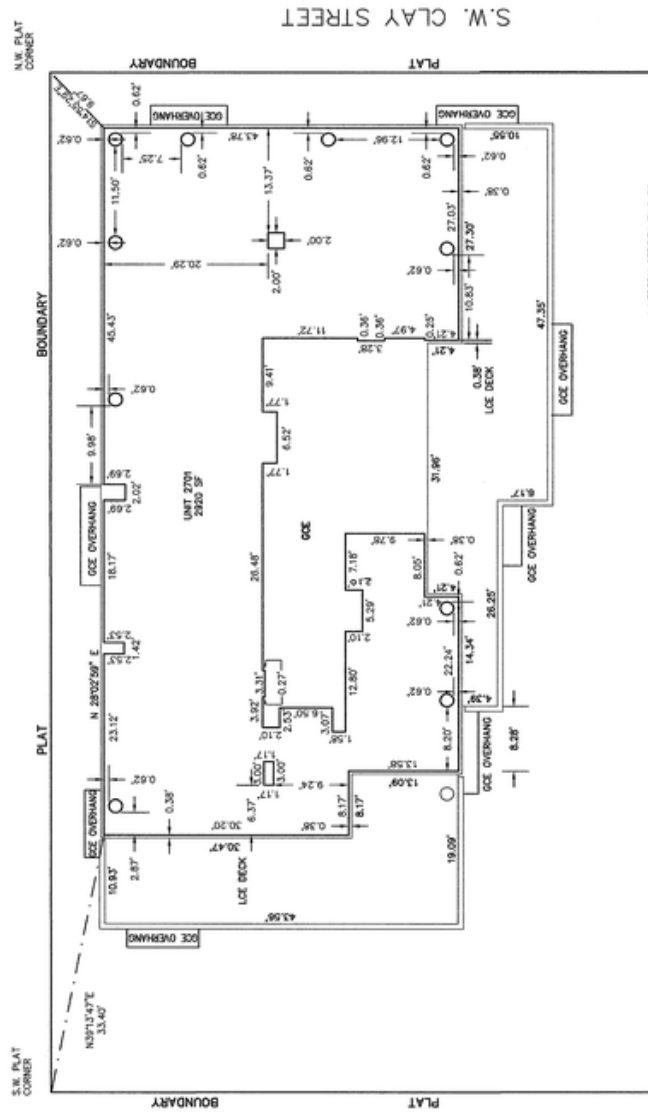

I HEREBY CERTIFY THIS TO BE A TRUE AND CORRECT COPY OF THE ORIGINAL PLAT.

THIS SURVEY WAS PREPARED USING INSTRUMENTS CALIBRATED BY THE OREGON SURVEYING BOARD PRODUCT NO. 21898A ON GCE 86342 POLYESTER FILM



SCALE: 1"=10'

DATE: 04-21-07
 REGISTERED PROFESSIONAL LAND SURVEYOR
 E. MASHI
 OREGON
 JANUARY 14, 2003
 TIMOTHY M. ALDROR
 EXPIRES 12-31-07

**FLOOR PLAN
 LEVEL 27**

KURAHASHI & ASSOCIATES, INC.
 Civil Engineering • Water Resources
 Landscape Architecture • Planning
 Environmental • Surveying
 4470 SW Hall Blvd, Suite C
 Portland, Oregon 97206
 (503)944-6662 Fax: (503)944-9771

BENSON TOWER CONDOMINIUM
 A PORTION OF LOT 6, AND ALL OF LOT 7 & 8,
 BLOCK 243, "CITY OF PORTLAND"
 LOCATED IN THE NORTHEAST 1/4 OF SECTION 4
 TOWNSHIP 1 SOUTH, RANGE 1 EAST
 WILLAMETTE MERIDIAN, CITY OF PORTLAND
 MULTNOMAH COUNTY, OREGON
 SHEET 22 OF 23

APRIL 02, 2007

LEGEND

VM - DENOTES VERTICAL HEIGHT OF CEILING
 VM - DENOTES VERTICAL HEIGHT OF COMMON ELEMENT
 LCE - DENOTES LIMITED COMMON ELEMENT

NOTES:

1. ALL WALL ANGLES ARE 90° UNLESS NOTED OTHERWISE.
2. SEE SHEET 2 FOR FLOOR ELEVATIONS.

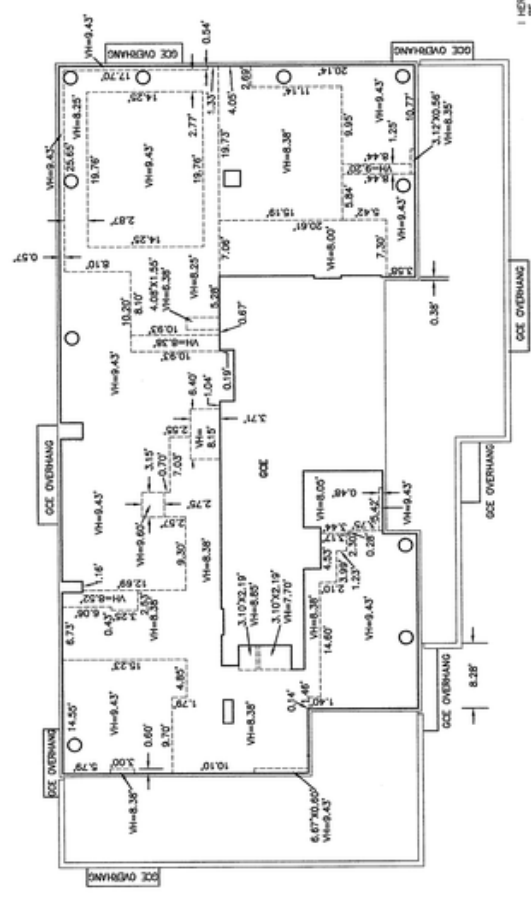

THIS SURVEY WAS REGISTERED TO THE PUBLIC RECORDS OF MULTNOMAH COUNTY, OREGON, PRODUCT NO. 516404, ON 07/25/06 BY POLYSTAR FILM DATE 06-21-07

REGISTERED PROFESSIONAL LAND SURVEYOR
 TIMOTHY H. ALDOVER
 53335
 EXPIRES 12-31-07



CEILING PLAN
LEVEL 27

KURAHASHI & ASSOCIATES, INC.
 Civil Engineering • Water Resources
 Environmental • Surveying
 4470 SW Hall Blvd, Suite C
 Beaverton, Oregon 97005
 (503)644-8612 fax: (503)644-9728

After recording return to:
Karna R. Gustafson
LANDYE BENNETT BLUMSTEIN LLP
1300 SW Fifth Avenue, Suite 3500
Portland, OR 97201

Multnomah County Official Records	2012-164514
R Weldon, Deputy Clerk	12/19/2012 12:56:33 PM
1R-AMDECUO Pgs=5 Stn=1 ATWJH	\$61.00
\$25.00 \$11.00 \$10.00 \$15.00	

**AMENDMENT TO THE DECLARATION
SUBMITTING BENSON TOWER CONDOMINIUM
TO CONDOMINIUM OWNERSHIP**

RECITALS

The Declaration Submitting Benson Tower Condominium to Condominium Ownership was recorded as Fee No. 2007-113469 in the deed records of Multnomah County, Oregon, on June 25, 2007, by the Declarant, The Benson Tower, LLC, an Oregon limited liability company.

Members of the Benson Tower Condominium Owners Association ("Association") have voted to amend the Declaration to restrict the leasing of units to enhance the availability of purchase-money financing, and to provide a procedure for enforcing such restriction, maintaining a record of units being leased, and maintaining a waiting list of unit owners that wish to lease their units.

This rental restriction shall not apply to any person who is an owner as of the date this amendment is recorded, but shall apply to current owners' successors in interest and any person purchasing a Living Unit after this amendment is recorded.

AMENDMENT

The Declaration Article 10, Section 10.1 shall be deleted and replaced in its entirety as follows:

"10.1 Use of Units. The Living Units shall be occupied and used by the respective owners only for residential purposes for the owner, family, tenant and social guests and for no other purposes. Any lease or rental agreement shall be subject to the terms and provisions contained in this Declaration, the Bylaws, and the rules and regulations of the Association. Subject to the exception for existing owners as provided by Section 10.1.2 below, not more than twenty-five percent (25%) of all Living Units may be non-owner occupied, except in the case of hardship where such percent may increase to thirty percent (30%) as set forth herein.

10.1.1 Leasing Restriction. No owner may lease or rent less than his/her entire Living Unit unless the owner remains in occupancy and no such owner may rent his/her Living Unit for transient or motel purposes. All leases and rental agreements must be in writing. With the exception of a lender in possession of a Living Unit following default in a first mortgage, a

foreclosure proceeding or any deed or other arrangement in lieu of foreclosure, no Living Unit owner may rent or lease his/her Living Unit for a period of less than twelve (12) months. Provided, however, any 12-month or longer lease may be extended beyond such term on a month-to-month basis. Provided, further, except in the event of a hardship, as defined below, the maximum number of Living Units that may be non-owner occupied shall not exceed twenty-five percent (25%) of all Living Units. Occupancy shall be limited to the lessees, their household members, visitors and guests. Except as provided in this Section, any owner of a Living Unit acquiring such unit after the date this amendment is recorded may not enter into any rental arrangement for such unit except in compliance with this Section. "Owner-Occupied" shall mean any period during which the unit is vacant or occupied by an owner or an owner's spouse, children, or parents as a primary or secondary residence and no rent is charged such occupants.

10.1.2 Existing Owners. The restriction on renting or leasing units shall not apply to any Living Unit owner that, as of the date of recording hereof, is a current owner of a Living Unit, hereinafter referred to as an "Exempt Unit." However, the leased Living Unit shall count towards the twenty-five percent (25%) or thirty percent (30%) threshold, whichever is applicable, for purposes of calculating whether a person purchasing a Living Unit after the date of recording hereof may rent their Living Unit. An owner with one Exempt Unit is not entitled to the exemption with respect to any other Living Unit acquired after the date this amendment is recorded. The renting restrictions contained in this Section apply independently to each Living Unit owned by an owner and exemptions may not be transferred to an owner's successors and assigns, including, but not limited to, persons who acquire a Living Unit through inheritance or gift.

10.1.3 Hardship. If the twenty-five percent (25%) threshold set forth in subparagraph 10.1.1 has already been reached, a unit owner may apply to the Board of Directors for a hardship-based exception to the twenty-five percent (25%) threshold; provided, however, that no hardship-based exception shall be granted if doing so causes the non-owner occupancy rate to exceed thirty percent (30%) of all Living Units. The following situations may be considered for hardship-based exceptions: (1) if the owner or his/her spouse relocates for work or educational purposes; (2) if the owner dies, is hospitalized for a protracted illness, or is placed in a nursing home or a convalescent home or other facility or with family members due to illness; (3) if inability to rent a Living Unit will result in serious financial hardship to the owner; and (4) such other extraordinary circumstances which the Board of Directors deems a hardship. The Board of Directors, in its sole and unfettered discretion, shall determine whether an owner's situation meets any of the factual situations set forth above and thus qualifies for a hardship-based exception. It may then grant such exception only if doing so would not cause the percentage of tenant occupancy of Living Units to exceed thirty percent (30%).

10.1.4 Procedure. Prior to entering into any lease agreement, a Living Unit owner shall notify the Board of Directors in writing of his/her intent to lease or rent such owner's unit and the name and address of the proposed tenant. Within fifteen (15) days of such notification, the Board shall advise the owner of whether such proposed tenancy would or would not exceed the twenty-five percent (25%) restriction and, if it would exceed such restriction, the Board shall place the owner on a waiting list and shall notify such owner when such owner's Living Unit may be rented. Provided, however, an owner on the waiting list may apply for a hardship

exemption if such owner believes the circumstances are appropriate for such an exemption. Once a Living Unit owner is notified that his/her unit may be rented, such owner, within six (6) months from the date of such notice, shall enter into a twelve (12) month lease with a tenant. If a notified owner has not entered into such a lease within such period, the Board shall place such owner at the end of the waiting list and shall notify the next owner on such list that he may rent his/her Living Unit. An owner that receives permission from the Board to rent his/her Living Unit may continue to rent such Living Unit upon the expiration or termination of each tenancy, provided that, if for any period exceeding sixty (60) days the Living Unit becomes Owner-Occupied, the owner no longer may rent the Living Unit and shall reapply to the Board.

10.1.5 Compliance with Documents. Tenants of all owners, including tenants of an Exempt Unit, shall be subject to the terms of the Declaration, Bylaws, and Rules and Regulations of the Association and the Board of Directors. Each lease agreement shall provide that the terms of the lease shall be subject in all respects to the provisions of the Declaration, Bylaws, and Rules and Regulations and that any failure by a lessee to comply with the terms thereof shall be a default under the lease. By becoming a tenant, each tenant agrees to be bound by the Declaration, Bylaws, and Rules and Regulations of the Association, regardless or whether such provisions are part of the lease, and recognizes and accepts the right and power of the Association to evict a tenant for any violation by the tenant of the Declaration, Bylaws, and Rules and Regulations of the Association. Each tenant shall be provided copies of the Declaration, Bylaws and Rules and Regulations by the owner of the Living Unit being leased at the beginning of the lease term and thereafter with any amendments to such documents. A Living Unit owner may be assessed personally for any expenses incurred by the Association resulting from damage to the common elements caused by such owner's tenant. After giving notice and an opportunity to be heard, owners may be fined for their tenant's noncompliance with any provision of the Declaration, Bylaws and Rules and Regulations, and such fines shall be collectible as assessments as elsewhere provided in the Bylaws. The Living Unit owner shall provide a fully executed copy of each lease to the Board of Directors. All owners leasing their Living Unit shall promptly notify the Association of the address and telephone number where such owner can be reached. All owners, including owners of Exempt Units, are subject to this subsection.

10.1.6 Enforcement. If a Living Unit owner fails to follow the procedures set forth in this Section with respect to the leasing of his Living Unit, at any time after learning of such leasing, the Board of Directors may charge such owner an administrative fee, the amount of which shall be determined from time to time by Board resolution. The purpose of the fee is to reimburse the Association for time, costs and expenses of management time incurred to obtain information about the tenant and to provide such tenant with copies of Association documents. Provided, however, that charging an owner an administrative fee and/or providing such owner's tenant with copies of Association documents shall not bar or limit the Association's remedies arising from such owner's violations of the provisions of the Declaration, Bylaws and Rules and Regulations, including, without limitation, the right to sue for an injunction, for damages and to remove the tenant in the event that the tenancy violates any provision of this Section.

If any tenant is in violation of the provisions of the Declaration, Bylaws, or Rules and Regulations of the Association, the Association may bring an action in its own name and/or in

3rd The foregoing Amendment to Declaration is approved pursuant to ORS 100.110 this day of December, 2012 and, in accordance with ORS 100.110(7), this approval shall automatically expire if these amendments are not recorded within one (1) year from this date.

REAL ESTATE COMMISSIONER

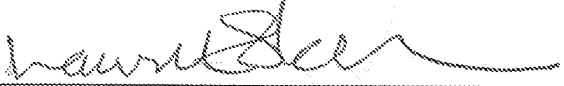
By: 

The foregoing Amendment to Declaration is approved pursuant to ORS 100.110 this 11th day of December, 2012.

COUNTY ASSESSOR

By: 

After recording return to:
Karna R. Gustafson
LANDYE BENNETT BLUMSTEIN LLP
1300 SW Fifth Avenue, Suite 3500
Portland, OR 97201

Multnomah County Official Records **2012-164513**
R Weldon, Deputy Clerk
12/19/2012 12:56:33 PM
1R-AMBYLAWS Pgs=2 Stn=1 ATWJH
\$10.00 \$11.00 \$10.00 \$15.00 \$46.00

**AMENDMENT TO BYLAWS
OF THE
BENSON TOWER CONDOMINIUM OWNERS ASSOCIATION**

RECITALS

The Bylaws of the Benson Tower Condominium Owners Association were recorded in the deed records of Multnomah County, Oregon, on June 25, 2007, simultaneously with the Declaration as Exhibit C, Fee No. 2007-113469, by the Declarant, The Benson Tower, LLC, an Oregon limited liability company.

Members of the Benson Tower Condominium Owners Association ("Association") have voted to amend the Bylaws to restrict the leasing of units consistent with the Amendment to the Declaration Submitting Benson Tower Condominium to Condominium Ownership ("Declaration") recorded simultaneously herewith.

AMENDMENT

Article 7, Section 7.6 is deleted and replaced in its entirety as follows:

"7.6 Leasing and Rental of Units. No unit owner may lease or rent less than his or her entire unit and no unit owner may rent such owner's unit for transient or hotel purposes. All owners must also comply with Article 10 of the Declaration concerning rental and lease restrictions."

It is hereby certified that the foregoing amendment has been approved by seventy-five percent (75%) of the Association members as required by the Bylaws and Oregon Condominium Act.

DATED: 12-13-12

BENSON TOWER CONDOMINIUM
OWNERS ASSOCIATION

By: 
Chairperson

By: 
Secretary

STATE OF OREGON)
) ss.
County of Multnomah)

December 13, 2012

Personally appeared before me the above-named Jim Werner
and Lana Lamash who, being duly sworn, did say that they are the
Chairperson and Secretary of the Benson Tower Condominium Owners Association and that said
instrument was signed in behalf of said Association by authority of its Board of Directors; and
they acknowledged said instrument to be its voluntary act and deed.

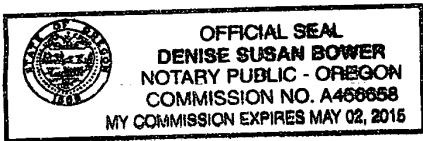

Denise Susan Bower
Notary Public for Oregon

AFTER RECORDING, RETURN TO:

SAME AS BELOW

Recorded in MULTNOMAH COUNTY, OREGON
C. Swick, Deputy Clerk
E41 71
Total : 371.00

ATVLM

2007-113469 06/25/2007 01:44:05pm

PREPARED BY:

Howard M. Feuerstein
Stoel Rives LLP
900 SW Fifth Avenue, Suite 2600
Portland, Oregon 97204

**DECLARATION SUBMITTING
BENSON TOWER CONDOMINIUM
TO CONDOMINIUM OWNERSHIP**

THE BENSON TOWER, LLC,
an Oregon limited liability company
Declarant

TABLE OF CONTENTS

		Page
Article 1	DEFINITIONS.....	1
1.1	“Association”	1
1.2	“Bylaws”	1
1.3	“Condominium”	1
1.4	“Declarant”	1
1.5	“Declaration”	1
1.6	“Living Units”.....	1
1.7	“Mortgage” and “Mortgagee”	1
1.8	“Parking Units”.....	1
1.9	“Plat”.....	2
1.10	“Storage Units”.....	2
1.11	Incorporation by Reference.....	2
Article 2	SUBMISSION OF PROPERTY TO CONDOMINIUM STATUTE.....	2
Article 3	NAME OF CONDOMINIUM.....	2
Article 4	UNITS.....	2
4.1	General Description of Buildings.	2
4.2	General Description, Location and Designation of Units	2
4.3	Boundaries of Units.	3
(a)	Living Units.	3
(b)	Parking Units.	3
(c)	Storage Units.....	3
Article 5	GENERAL COMMON ELEMENTS.....	3
Article 6	LIMITED COMMON ELEMENTS.....	4
Article 7	ALLOCATION OF UNDIVIDED INTERESTS IN COMMON ELEMENTS.....	4
Article 8	COMMON PROFITS AND EXPENSES; VOTING	4
8.1	Allocation of Common Profits and Expenses.....	4
8.2	Allocation of Voting Rights.....	4
Article 9	SERVICE OF PROCESS	5
Article 10	USE OF PROPERTY	5

10.1	Living Units.....	5
10.2	Parking Units.....	5
10.3	Storage Units.....	5
Article 11	MAINTENANCE OF COMMON ELEMENTS.....	5
11.1	Responsibility for Maintenance.....	5
11.2	Mortgagee's Rights upon Failure to Maintain.....	5
11.3	Rights of City of Portland Upon Failure to Maintain.....	6
Article 12	EASEMENTS.....	6
12.1	In General.....	6
12.2	Encroachments.....	6
12.3	Granting of Easements by Association.....	7
12.4	Right of Entry.....	7
12.5	Easements for Declarant.....	7
Article 13	APPROVAL BY MORTGAGEES.....	7
13.1	Notice of Action.....	7
13.2	Termination and Amendment to Documents.....	8
13.3	Additional Approvals.....	8
13.4	Notice to First Mortgagees of Defaults.....	9
Article 14	ASSOCIATION OF UNIT OWNERS.....	9
14.1	Organization.....	9
14.2	Membership; Board of Directors.....	9
14.3	Powers and Duties.....	9
14.4	Adoption of Bylaws, Declarant Control of Association.....	9
Article 15	RELOCATION OF BOUNDARIES.....	9
15.1	Approval.....	9
15.2	Powers of Board.....	10
15.3	Amendment.....	10
Article 16	AMENDMENT.....	10
16.1	How Proposed.....	10
16.2	Approval Required.....	10
16.3	Recordation.....	11
Article 17	SEVERABILITY.....	11
Article 18	APPLICABILITY.....	11

**DECLARATION SUBMITTING
BENSON TOWER CONDOMINIUM
TO CONDOMINIUM OWNERSHIP**

THIS DECLARATION, pursuant to the provisions of the Oregon Condominium Act, is made and executed this ____ day of April, 2007, by **THE BENSON TOWER, LLC**, an Oregon limited liability company (“**Declarant**”).

Declarant proposes to create a condominium to be known as Benson Tower Condominium, that will be located in the City of Portland, Multnomah County, Oregon. The purpose of this Declaration is to submit the property described in Article 2 below to the condominium form of ownership and use in the manner provided by the Oregon Condominium Act.

NOW, THEREFORE, Declarant does hereby declare and provide as follows:

Article 1

DEFINITIONS

When used in this Declaration the following terms shall have the following meanings:

1.1 “**Association**” means the association of unit owners established pursuant to Article 14 below.

1.2 “**Bylaws**” means the Bylaws of Benson Tower Condominium Owners Association adopted pursuant to Section 14.4 below as the same may be amended from time to time.

1.3 “**Condominium**” means all of that property submitted to the condominium form of ownership by this Declaration.

1.4 “**Declarant**” means The Benson Tower, LLC, an Oregon limited liability company, and its successors and assigns.

1.5 “**Declaration**” means this Declaration as the same may hereafter be amended.

1.6 “**Living Units**” means those dwelling units labeled as such in the attached Exhibit B.

1.7 “**Mortgage**” and “**Mortgagee**” mean, respectively, a recorded mortgage, trust deed or contract of sale that creates a lien against a unit, and the holder, beneficiary or vendor of such a mortgage, trust deed or contract of sale.

1.8 “**Parking Units**” means those units for parking of vehicles labeled as such in the attached Exhibit B.

1.9 “**Plat**” means the plat of Benson Tower Condominium recorded simultaneously with the recording of this Declaration.

1.10 “**Storage Units**” means any units for storage purposes labeled as such in the attached Exhibit B.

1.11 **Incorporation by Reference**. Except as otherwise provided in this Declaration, each of the terms defined in ORS 100.005, a part of the Oregon Condominium Act, shall have the meanings set forth in such section.

Article 2

SUBMISSION OF PROPERTY TO CONDOMINIUM STATUTE

The property submitted to the Oregon Condominium Act by this Declaration is held by Declarant and conveyed by Declarant in fee simple estate. The land submitted is located in the City of Portland, Multnomah County, Oregon, and is more particularly described in the attached Exhibit A. The property submitted includes the land so described, all buildings, improvements and structures, all easements, and rights and appurtenances located on, belonging to or used in connection with such land, including right to use portions of areas under adjoining street rights of way pursuant to Revocable Permit to Use Dedicated Street Areas dated December 15, 2004 and recorded April 18, 2005, as Document No. 2005-067634, Records of Multnomah County Oregon.

Article 3

NAME OF CONDOMINIUM

The name by which the Condominium shall be known is “**Benson Tower Condominium.**”

Article 4

UNITS

4.1 **General Description of Buildings**. The Condominium consists of one building of dwelling units. The building contains 26 stories above grade with a basement of four and one-half stories below grade. The building is of reinforced concrete construction with glass curtain wall exterior and a two-ply built up membrane roof.

4.2 **General Description, Location and Designation of Units**. The Condominium contains 143 Living Units, 153 Parking Units and 108 Storage Units for a total of 404 units. The designation, location, description of boundaries and area in square feet of each unit are shown on the Plat and the attached Exhibit B.

4.3 **Boundaries of Units.**

(a) **Living Units.** Each Living Unit shall be bounded by the interior surfaces of its perimeter and bearing walls, floors, ceilings, windows and window frames, doors and door frames, and trim. The Living Units shall include all lath, furring, wallboard, plasterboard, plaster, paneling, tiles, wallpaper, paint, finished flooring and any other materials constituting any part of its finished surfaces, except those portions of the walls, floors or ceilings that materially contribute to the structural or shear capacity of the Condominium. All other portions of the walls, floors or ceilings shall be a part of the common elements. In addition, each unit shall include the following: (a) All spaces, nonbearing interior partitions, interior doors and door frames and all other fixtures and improvements within the boundaries of the unit; and (b) All outlets of utility and communications service lines, including but not limited to power, light, gas, hot and cold water, heating, refrigeration, air conditioning and waste disposal, security, cable television and telephone, within the boundaries of the unit, but shall not include any part of such lines or ducts themselves.

(b) **Parking Units.** Parking Units are bounded by the surface of floors, perimeter walls (if any) and, except as otherwise indicated on the Plat, a horizontal plane seven feet above the floor. Parking Units without perimeter walls are bounded by a vertical plane at the boundary shown on the Plat. Parking Units do not include the floor, ceiling or perimeter walls themselves.

(c) **Storage Units.** Storage Units are bounded by the surface of the bottoms, perimeter walls and, except as otherwise indicated on the Plat, a horizontal plane seven feet above the floor. Storage Units do not include the bottoms, tops or perimeter walls themselves.

Article 5

GENERAL COMMON ELEMENTS

The general common elements consist of all portions of the Condominium that are not part of a unit or a limited common element, including, but not limited to, the following:

5.1 The land, grounds, and the garage structure.

5.2 Pipes, ducts, flues, chutes, conduits, wires and other utility and communications installations to their outlets.

5.3 Roofs, foundations, bearing and shear walls, perimeter walls, beams, columns and girders to the interior surfaces thereof, exterior doors and door frames, window glass and window frames.

5.4 Stairways, landings, hallways, lobbies, elevators, the reading room, the spa facility, the fitness room, and entrances and exits that are not part of a unit.

5.5 All other elements of the buildings and the Condominium necessary or convenient to their existence, maintenance and safety, or normally in common use, except as may be expressly designated in this Declaration as part of a unit or a limited common element.

Article 6

LIMITED COMMON ELEMENTS

The following shall constitute limited common elements, the use of which shall be restricted to the units to which they pertain: All decks, each of which shall pertain to the unit that it adjoins as shown on the Plat.

Article 7

ALLOCATION OF UNDIVIDED INTERESTS IN COMMON ELEMENTS

Each unit will be entitled to an undivided ownership interest in the common elements determined by the ratio by which the square footage of the particular unit bears to the total square footage of all units combined, as shown on the attached Exhibit B. Each unit's interest in the common elements shall be inseparable from the unit and any conveyance, encumbrance, judicial sale, or other transfer, voluntary or involuntary, of an undivided interest in the common elements shall be void unless the unit to which that interest is allocated is also transferred.

Article 8

COMMON PROFITS AND EXPENSES; VOTING

8.1 **Allocation of Common Profits and Expenses.** The common profits and common expenses of the Condominium shall be allocated to the owner of each unit according to the allocation of undivided interest of such unit in the common elements; provided, however, that upon the sale of each unit to a person other than a successor declarant, the purchaser shall make a contribution to the working capital of the Association equal to two month's of regular Association assessments for the unit as further described in the Bylaws. Except upon termination of the Condominium or as otherwise provided in the Bylaws with respect to damage, destruction or condemnation, any such common profits shall be used solely for the purpose of maintaining, repairing and replacing the common elements or for other expenses or reserves of the Association.

8.2 **Allocation of Voting Rights.** Each unit owner shall be entitled to one vote in the affairs of the Association and for the purposes of this Declaration for each Living Unit owned by such owner; provided, however, that Declarant shall have five votes for each Living Unit owned by Declarant until the earlier of (a) when Declarant has sold and conveyed to a person other than a successor declarant 75 percent or more of the Living Units in the Condominium, or (b) three years after the date of the first conveyance of a unit to a person other than a successor declarant. No voting rights shall attach to Parking Units or Storage Units. The method of voting shall be as specified in the Bylaws.

Article 9

SERVICE OF PROCESS

The designated agent to receive service of process in cases provided in subsection (1) of ORS 100.550 is named in the Condominium Information Report that has been filed in accordance with ORS 100.250(1)(a).

Article 10

USE OF PROPERTY

Each unit is to be used for the purposes set forth below. Additional limitations on use are contained in the Bylaws and the rules and regulations adopted pursuant to the Bylaws. Each unit owner shall be bound by each of such documents.

10.1 **Living Units**. Living Units shall be used primarily for residential purposes as defined in the Bylaws.

10.2 **Parking Units**. Parking Units may be used only for parking of vehicles and may be owned only by Declarant, the Association or the owner of a Living Unit in the Condominium. Parking Units may not be used as a residence or by any person other than Declarant, the Association or an owner, occupant or guest of a Living Unit in the Condominium. Transfer of Parking Units by Declarant or by or among unit owners shall be accomplished by deed or other form of real property conveyance instrument.

10.3 **Storage Units**. Storage Units may be used only for storage purposes and may be owned only by Declarant, or by the owner of a Living Unit in the Condominium and used in connection with the use of such a unit. Storage Units may not be used by any person other than Declarant or an owner or tenant of a Living Unit in the Condominium. Transfer of Storage Units by Declarant or by or among unit owners shall be accomplished by deed or other form of real property conveyance instrument. The Association by rule may regulate storage of hazardous or flammable substances in Storage Units.

Article 11

MAINTENANCE OF COMMON ELEMENTS

11.1 **Responsibility for Maintenance**. The necessary work to maintain, repair or replace the common elements shall be the responsibility of the board of directors of the Association and shall be carried out as provided in the Bylaws.

11.2 **Mortgagee's Rights upon Failure to Maintain**. If the Mortgagee of any unit determines that the board of directors is not providing an adequate maintenance, repair and replacement program for the common elements, such Mortgagee, at its option, may give a notice to the board of directors by delivering same to the registered agent, setting forth the particular defect that it believes exists in the maintenance, repair and replacement program. If the specified

defects are not corrected within 90 days subsequent to receipt of such notice, then the Mortgagee, upon written notice to the registered agent that it is exercising its proxy rights, shall have the right to attend succeeding annual or special meetings of the Association and to cast a vote for each unit on which it holds a Mortgage on all business coming before such meeting. Such proxy rights shall continue until the defects listed on the notice are corrected.

11.3 **Rights of City of Portland Upon Failure to Maintain.** The provisions of this Declaration and of the Bylaws regarding the maintenance, repair and replacement of the common elements shall be deemed to be for the benefit of the City of Portland, as well as the unit owners, and the City may enforce such provisions by appropriate proceedings at law or in equity. Without limitation to the foregoing, the City may deliver a written notice to the board of directors by delivering the same to the registered agent, setting forth the particular defect that it believes exists in the maintenance, repair and replacement program. If the specified defects are not corrected within 30 days after receipt of the notice, or, if such correction cannot reasonably be completed within such time, the Association fails within such time to commence and pursue the correction with reasonable diligence, then the City may take necessary curative action. In such event, the cost of correction by the City shall constitute a lien against each unit and its interest in the common elements based upon such unit's share of the common expenses as provided in this Declaration.

Article 12

EASEMENTS

12.1 **In General.** Each unit has an easement in and through each other unit and the common elements for all support elements and utility, wiring, heat, plumbing, and service elements, and for reasonable access thereto, as required to effectuate and continue proper operation of the Condominium, including, without limitation, easements as required for the electrical wiring and plumbing for each unit. The specific mention or reservation of any easement in this Declaration does not limit or negate the general easement for common elements reserved by law. Each unit owner has an unrestricted right of ingress and egress to his or her unit. This right is perpetual and passes with the ownership of the unit.

12.2 **Encroachments.** Each unit and all common elements shall have an easement over all adjoining units and common elements for the purpose of accommodating any present or future encroachment as a result of engineering errors, construction, reconstruction, repairs, settlement, shifting, or movement of any portion of the property, or any other similar cause, and any encroachment due to building overhang or projection. There shall be valid easements for the maintenance of the encroaching units and common elements so long as the encroachments shall exist, and the rights and obligations of owners shall not be altered in any way by the encroachment. This provision does not relieve a unit owner of liability in the case of willful misconduct of the unit owner, or relieve Declarant or any contractor, subcontractor or materialman from any liability as a result of failure to adhere to the Plat. The encroachments described in this Section 12.2 shall not be construed to be encumbrances affecting the marketability of title to any unit.

12.3 **Granting of Easements by Association.** Subject to the requirements of ORS 100.405(6), the Association may grant, execute, acknowledge, deliver and record on behalf of the unit owners leases, easements, rights-of-way, licenses, and similar interests affecting the common elements and consent to vacation of roadways within and adjacent to the Condominium. Any such instrument shall be executed by the chairperson and secretary of the Association. No such interest may be granted with regard to a limited common element unless the owners and Mortgagees of the units having the right to use such limited common element consent to and join in the instrument granting the interest.

12.4 **Right of Entry.** The board of directors of the Association, managing agent, manager or any other person authorized by the board of directors shall have the right to enter any unit and limited common element in the case of an emergency originating in or threatening such unit or other condominium property, whether or not the owner is present at the time. Such persons shall also have the right to enter any unit and limited common element for the purpose of performing installations, alterations or repairs to any common element and for the purpose of inspection to verify that the unit owner is complying with the restrictions and requirements described in this Declaration and the Bylaws, provided that requests for entry are made in advance and that such entry is at a time convenient to the owner.

12.5 **Easements for Declarant.** Declarant and Declarant's agents, successors and assigns shall have an easement over and upon the common elements as may be reasonably necessary for the purpose of completing or making repairs to existing structures for the purpose of carrying out sales and rental activities necessary or convenient for the sale or rental of units, including, without limitation, the right to use the units owned by Declarant as model units and the right to use a unit as a sales office, and for the purpose of discharging any other obligation of Declarant or exercising any other special Declarant right, whether arising under the Oregon Condominium Act or reserved in this Declaration or the Bylaws. For a period of ten (10) years following recording of this Declaration, Declarant shall have a right to inspect the common elements of the Condominium and the Association's records regarding inspections and maintenance of the Condominium.

Article 13

APPROVAL BY MORTGAGEES

13.1 **Notice of Action.** Upon written request to the Association identifying the name and address of the holder, insurer or guarantor and the unit number or address of the unit on which it has (or insures or guarantees) the Mortgage, any such Mortgagee shall be entitled to timely written notice of the following:

(a) Any condemnation or casualty loss that affects a material portion of the Condominium or affects the unit securing its Mortgage.

(b) Any 60-day delinquency in the payment of assessments or charges owed by an owner of any unit on which it holds the Mortgage.

(c) Any lapse, cancellation or material modification of any insurance policy maintained by the Association.

(d) Any proposed action that would require consent of a specified percentage of Mortgagees as required by this article.

13.2 **Termination and Amendment to Documents.**

(a) Unless a greater vote is required by this Declaration, the Bylaws or the Oregon Condominium Act, the approval of Mortgagees holding Mortgages on units that have at least 51 percent of the voting rights of units subject to Mortgages shall be required to terminate the legal status of the project as a condominium.

(b) Except when a greater percent is required by the Declaration or Bylaws, or a greater or lesser percent is required by the Oregon Condominium Act, the consent of the Mortgagees holding Mortgages on units that have at least 51 percent of the voting rights of the units subject to Mortgages shall be required for any amendments to the Declaration or Bylaws of a material adverse nature to the Mortgagees.

(c) An addition or amendment to the Declaration or Bylaws shall not be considered material or adverse for purposes of Section 13.2(b) if it is for the purpose of correcting technical errors, or for clarification only. Any Mortgagee who receives a written request to approve any termination, additions or amendments and who does not deliver or post to the requesting party a negative response within 60 days shall after it receives proper notice of the proposal, provided the notice was delivered by certified or registered mail, return receipt requested, be deemed to have approved such request.

13.3 **Additional Approvals.** In addition to any other or greater approvals required by the Oregon Condominium Act, this Declaration or the Bylaws, the prior written approval of two-thirds of the holders of first Mortgages on units in the Condominium (based upon one vote for each first Mortgage owned) or unit owners (other than Declarant) must be obtained for the following:

(a) Abandonment or termination of the Condominium regime.

(b) Except as otherwise provided in Section 15.1, any change in the pro rata interest or obligations of any individual unit for (a) purpose of levying assessments or charges or allocating distributions of hazard insurance proceeds or condemnation awards, or (b) determining the pro rata share of ownership of each unit in the common elements.

(c) The partition or subdivision of any unit, except as otherwise provided in Article 15.

(d) Abandonment, partition, subdivision, encumbrance, sale or transfer of the common elements. The granting of easements for public utilities or for other public purposes consistent with the intended use of the common elements by the condominium project shall not be deemed a transfer within the meaning of this clause.

(e) Use of hazard insurance proceeds for losses to any condominium property, whether to units or to common elements, for other than the repair, replacement or reconstruction of such improvements, except as provided by statute in cases of substantial loss to the units and/or common elements of the condominium project.

13.4 **Notice to First Mortgagees of Defaults**. Any first Mortgagee, upon request, will be entitled to written notification from the Association of any default in the performance by the owner of the Mortgaged unit of any obligation under this Declaration, the rules and regulations or the Bylaws that is not cured within 60 days.

Article 14

ASSOCIATION OF UNIT OWNERS

14.1 **Organization**. Upon the recording of this Declaration an association of unit owners shall be organized to serve as a means through which the unit owners may take action with regard to the administration, management and operation of the Condominium. The name of this association shall be "Benson Tower Condominium Owners Association," and the Association shall be an Oregon nonprofit corporation.

14.2 **Membership; Board of Directors**. Each unit owner shall be a member of the Association. The affairs of the Association shall be governed by a board of directors as provided in the Bylaws.

14.3 **Powers and Duties**. The Association shall have such powers and duties as may be granted to it by the Oregon Condominium Act, including each of the powers set forth in ORS 100.405(4), together with such additional powers and duties afforded it by this Declaration or the Bylaws.

14.4 **Adoption of Bylaws, Declarant Control of Association**. Upon the execution and the recording of this Declaration, Declarant shall adopt Bylaws for the Association, which Bylaws are attached as Exhibit C. Declarant specifically reserves the right to control the Association by appointing the interim directors of the Association until the organizational and turnover meeting of the Association has been held and the unit owners have elected regular directors as provided in Sections 2.2 and 3.4 of the Bylaws. In addition, Declarant shall have the right to consent to any amendment to the Declaration or the Bylaws as provided in Section 16.2 below and Section 9.2 of the Bylaws, and a weighted vote in the Association as provided in Section 8.2 above.

Article 15

RELOCATION OF BOUNDARIES

15.1 **Approval**. The boundaries between adjoining units, including any intervening common elements, may be relocated or eliminated by an amendment to this Declaration. The owners of the affected units shall submit to the board of directors of the Association a proposed amendment that shall identify the units involved, state any reallocations of common element interest, voting rights, common expense liability and right to common profits and contain words

of conveyance. The board of directors shall approve the amendment unless it determines within 45 days that the reallocations are unreasonable or the relocation or elimination will impair the structural integrity or mechanical systems of the Condominium or lessen the support of any portion of the Condominium.

15.2 **Powers of Board.** The board of directors of the Association may require the owners of the affected units to submit an opinion of a registered architect or registered professional engineer that the proposed relocation or elimination will not impair the structural integrity or mechanical systems of the Condominium or lessen the support of any portion of the Condominium. The board of directors of the Association or any agent appointed by the board of directors may supervise the work necessary to effect the boundary relocation or elimination. Any expenses incurred under this section shall be charged to the owners of the units requesting the boundary relocation or elimination.

15.3 **Amendment.** The amendment shall be executed by the owners and Mortgagees of the affected units, certified by the chairperson and secretary of the Association, approved as required by law and recorded in the appropriate records of Multnomah County, Oregon. In addition, plat and floor plans necessary to show the altered boundaries between the adjoining units shall be recorded as required by law.

Article 16

AMENDMENT

16.1 **How Proposed.** Amendments to the Declaration shall be proposed by either a majority of the board of directors or by unit owners holding thirty percent (30%) or more of the voting rights. The proposed amendment must be reduced to writing and shall be included in the notice of any meeting at which action is to be taken thereon or attached to any request for consent to the amendment.

16.2 **Approval Required.** Except as may otherwise be provided in this Declaration or by the Oregon Condominium Act, this Declaration may be amended if such amendment is approved by unit owners holding 75 percent of the voting rights of the Condominium, without regard to any weighted vote otherwise allocable to units owned by Declarant, and by Mortgagees to the extent required by Article 13. Declarant's prior written consent shall also be required so long as Declarant owns 25 percent or more of the Living Units in the Condominium, but no such consent shall be required after 10 years from the date of conveyance of the first Living Unit to a person other than a successor declarant. Except as otherwise permitted by the Oregon Condominium Act, no amendment may change the size, location, allocation of undivided interest in the common elements, the method of determining liability for common expenses, the method of determining the right to common profits, or the method of determining voting rights of any unit unless such amendment has been approved by the owners and Mortgagees of the affected unit. Any amendment that would limit or diminish any special Declarant rights established in this Declaration or the Bylaws, including, without limitation, any amendment that could unreasonably interfere with the sale, lease or other disposition of units owned by Declarant or that could abridge, modify, eliminate or otherwise affect any right, power, easement, privilege or

benefit reserved for Declarant or which would impose any discriminatory charge or fee against Declarant, shall require the written consent of Declarant.

16.3 **Recordation.** The amendment shall be effective upon recordation in the Deed Records of Multnomah County, Oregon, of the Declaration as amended or of the amendment thereto, certified to by the chairperson and secretary of the Association as being adopted in accordance with this Declaration and the provisions of the Oregon Condominium Act, and approved by the county assessor and the Real Estate Commissioner if such approvals are required by the Oregon Condominium Act.

Article 17

SEVERABILITY

Each provision of this Declaration and the Bylaws shall be deemed independent and severable, and the validity or partial invalidity of any provision shall not affect the validity or enforceability of the remaining part of that or any other provision of this Declaration or the Bylaws.

Article 18

APPLICABILITY

Each unit owner, including Declarant as to any unsold unit, shall be subject to all of the rights and duties assigned to unit owners under the terms of the Declaration and Bylaws. All present and future owners, tenants, subtenants and occupants of units, and all present and future employees, agents, visitors and licensees of unit owners, shall be subject to and comply with the provisions of this Declaration, the Bylaws and all rules and regulations adopted thereunder, as they may be amended from time to time.

IN WITNESS WHEREOF, Declarant has caused this Declaration to be executed as of the day and year first set forth above.

THE BENSON TOWER, LLC,
an Oregon limited liability company

By: 
Keith Vernon, Authorized Signer

STATE OF OREGON)

County of Multnomah ss.

The foregoing instrument was acknowledged before me this 23rd day of April, 2007, by Keith Vernon, as Authorized Signer of The Benson Tower, LLC, an Oregon limited liability company, on behalf of such company.



Tracie A Massey
Notary Public for Oregon
My commission expires: 3/17/08
Commission No.: 376450

The foregoing Declaration is approved this 25th day of JUNE, 2007

ASSESSOR AND TAX COLLECTOR
FOR MULTNOMAH COUNTY

By [Signature]

The foregoing Declaration is approved pursuant to ORS 100.110 this 22nd day of June, 2007 and in accordance with ORS 100.110(7), this approval shall automatically expire if this Declaration is not recorded within two (2) years from this date.

REAL ESTATE COMMISSIONER

By [Signature]
Laurie Skillman

EXHIBIT A

Legal Description

A PORTION OF LOT 6 AND ALL OF LOT 7 & 8, BLOCK 243, "CITY OF PORTLAND," LOCATED IN THE NORTHEAST 1/4 OF SECTION 4, TOWNSHIP 1 SOUTH, RANGE 1 EAST, WILLAMETTE MERIDIAN, CITY OF PORTLAND, OREGON, SAID LAND BEING DESCRIBED AS FOLLOWS:

BEGINNING AT THE INITIAL POINT, BEING A 1" COPPER DISK IN CONCRETE STAMPED "KAI" SET TO REPLACE THE BRASS SCREW WITH 3/4" BRASS WASHER STAMPED "PUMPHRERY PLS 1677" PREVIOUSLY FOUND AT THE NORTHEAST CORNER OF LOT 8, BLOCK 243, "CITY OF PORTLAND", SAID POINT ALSO BEING ON THE SOUTHERLY RIGHT-OF-WAY LINE OF SW CLAY STREET (30 FEET FROM CENTERLINE WHEN MEASURED AT RIGHT ANGLES); THENCE, LEAVING SAID SOUTHERLY RIGHT OF WAY ALONG THE EASTERLY LINE OF SAID LOTS 8, 7 AND 6, SOUTH 28°00'00" WEST, A DISTANCE OF 130.00 FEET TO A 1" COPPER DISK IN CONCRETE STAMPED "KAI" SAID POINT BEING THE SOUTHEASTERLY CORNER OF THE NORTH 30.00 FEET OF SAID LOT 6; THENCE, ALONG THE SOUTH LINE OF THE NORTH 30.00 FEET LOT 6, BLOCK 243, "CITY OF PORTLAND" NORTH 62°00'00" WEST, A DISTANCE OF 100.00 FEET TO A 1" COPPER DISK SET IN CONCRETE STAMPED "KAI" ON THE EASTERLY RIGHT OF WAY LINE OF SW 11TH AVENUE; THENCE, ALONG THE SAID EASTERLY RIGHT OF WAY LINE NORTH 28°00'00" EAST, A DISTANCE OF 130.00 FEET TO THE SOUTHERLY RIGHT-OF-WAY LINE OF SW CLAY STREET AND A 1" COPPER DISK SET IN CONCRETE STAMPED "KAI"; THENCE, ALONG SAID SOUTHERLY RIGHT OF WAY LINE SOUTH 62°00'00" EAST, A DISTANCE OF 100.00 FEET TO THE INITIAL POINT.

TOGETHER WITH THOSE PORTIONS OF THE BUILDING WHICH EXTEND INTO THE PUBLIC RIGHTS-OF-WAY PURSUANT TO AN APPURTENANT RIGHT TO USE ADJOINING RIGHT-OF-WAY PER CITY OF PORTLAND PERMIT NUMBER TR-04-248 AS RECORDED IN DOCUMENT NO. 2005-067634.

EXHIBIT B**Unit Square Footages and Undivided Interests**

<u>Unit</u>	<u>Unit Type</u>	<u>Square Footage</u>	<u>Undivided Interest</u>
201	Living	994	994/140167
202	Living	721	721/140167
203	Living	532	532/140167
204	Living	716	716/140167
205	Living	504	504/140167
206	Living	604	604/140167
207	Living	705	705/140167
301	Living	1,004	1004/140167
302	Living	722	722/140167
303	Living	536	536/140167
304	Living	725	725/140167
305	Living	505	505/140167
306	Living	603	603/140167
307	Living	708	708/140167
401	Living	1,004	1004/140167
402	Living	722	722/140167
403	Living	536	536/140167
404	Living	725	725/140167
405	Living	505	505/140167
406	Living	603	603/140167
407	Living	708	708/140167
501	Living	1,004	1004/140167
502	Living	722	722/140167
503	Living	536	536/140167
504	Living	725	725/140167
505	Living	505	505/140167
506	Living	603	603/140167
507	Living	708	708/140167
601	Living	1,004	1004/140167
602	Living	722	722/140167
603	Living	536	536/140167
604	Living	725	725/140167
605	Living	505	505/140167
606	Living	603	603/140167
607	Living	708	708/140167
701	Living	1,004	1004/140167
702	Living	722	722/140167
703	Living	536	536/140167

<u>Unit</u>	<u>Unit Type</u>	<u>Square Footage</u>	<u>Undivided Interest</u>
704	Living	725	725/140167
705	Living	505	505/140167
706	Living	603	603/140167
707	Living	708	708/140167
801	Living	1,004	1004/140167
802	Living	722	722/140167
803	Living	536	536/140167
804	Living	725	725/140167
805	Living	505	505/140167
806	Living	603	603/140167
807	Living	708	708/140167
901	Living	1,004	1004/140167
902	Living	722	722/140167
903	Living	536	536/140167
904	Living	725	725/140167
905	Living	505	505/140167
906	Living	603	603/140167
907	Living	708	708/140167
1001	Living	1,004	1004/140167
1002	Living	722	722/140167
1003	Living	536	536/140167
1004	Living	725	725/140167
1005	Living	505	505/140167
1006	Living	603	603/140167
1007	Living	708	708/140167
1101	Living	1,004	1004/140167
1102	Living	722	722/140167
1103	Living	536	536/140167
1104	Living	725	725/140167
1105	Living	505	505/140167
1106	Living	603	603/140167
1107	Living	708	708/140167
1201	Living	1,004	1004/140167
1202	Living	722	722/140167
1203	Living	536	536/140167
1204	Living	725	725/140167
1205	Living	505	505/140167
1206	Living	603	603/140167
1207	Living	708	708/140167
1401	Living	1,004	1004/140167
1402	Living	722	722/140167
1403	Living	536	536/140167
1404	Living	725	725/140167
1405	Living	505	505/140167

<u>Unit</u>	<u>Unit Type</u>	<u>Square Footage</u>	<u>Undivided Interest</u>
1406	Living	603	603/140167
1407	Living	708	708/140167
1501	Living	1,095	1095/140167
1502	Living	910	910/140167
1503	Living	882	882/140167
1504	Living	1,248	1248/140167
1505	Living	638	638/140167
1601	Living	1,095	1095/140167
1602	Living	910	910/140167
1603	Living	882	882/140167
1604	Living	1,248	1248/140167
1605	Living	638	638/140167
1701	Living	1,095	1095/140167
1702	Living	910	910/140167
1703	Living	882	882/140167
1704	Living	1,248	1248/140167
1705	Living	638	638/140167
1801	Living	1,095	1095/140167
1802	Living	910	910/140167
1803	Living	882	882/140167
1804	Living	1,248	1248/140167
1805	Living	638	638/140167
1901	Living	1,095	1095/140167
1902	Living	910	910/140167
1903	Living	882	882/140167
1904	Living	1,248	1248/140167
1905	Living	638	638/140167
2001	Living	1,095	1095/140167
2002	Living	910	910/140167
2003	Living	882	882/140167
2004	Living	1,248	1248/140167
2005	Living	638	638/140167
2101	Living	1,051	1051/140167
2102	Living	796	796/140167
2103	Living	887	887/140167
2104	Living	1,250	1250/140167
2105	Living	625	625/140167
2201	Living	1,051	1051/140167
2202	Living	796	796/140167
2203	Living	887	887/140167
2204	Living	1,250	1250/140167
2205	Living	625	625/140167
2301	Living	1,051	1051/140167
2302	Living	796	796/140167

<u>Unit</u>	<u>Unit Type</u>	<u>Square Footage</u>	<u>Undivided Interest</u>
2303	Living	887	887/140167
2304	Living	1,250	1250/140167
2305	Living	625	625/140167
2401	Living	1,051	1051/140167
2402	Living	796	796/140167
2403	Living	887	887/140167
2404	Living	1,250	1250/140167
2405	Living	625	625/140167
2501	Living	1,051	1051/140167
2502	Living	796	796/140167
2503	Living	887	887/140167
2504	Living	1,250	1250/140167
2505	Living	625	625/140167
2601	Living	1,588	1588/140167
2602	Living	1,133	1133/140167
2603	Living	1,010	1010/140167
2701	Living	2,920	2920/140167
P-01	Parking	141	141/140167
P-02	Parking	136	136/140167
P-03	Parking	136	136/140167
P-04	Parking	136	136/140167
P-05	Parking	152	152/140167
P-06	Parking	144	144/140167
P-07	Parking	134	134/140167
P-08	Parking	158	158/140167
P-09	Parking	149	149/140167
P-10	Parking	156	156/140167
P-11	Parking	156	156/140167
P-12	Parking	138	138/140167
P-13	Parking	151	151/140167
P-14	Parking	151	151/140167
P-15	Parking	151	151/140167
P-16	Parking	151	151/140167
P-17	Parking	151	151/140167
P-18	Parking	151	151/140167
P-19	Parking	151	151/140167
P-20	Parking	151	151/140167
P-21	Parking	143	143/140167
P-22	Parking	139	139/140167
P-23	Parking	136	136/140167
P-24	Parking	148	148/140167
P-25	Parking	153	153/140167
P-26	Parking	145	145/140167
P-27	Parking	136	136/140167

<u>Unit</u>	<u>Unit Type</u>	<u>Square Footage</u>	<u>Undivided Interest</u>
P-28	Parking	136	136/140167
P-29	Parking	136	136/140167
P-30	Parking	136	136/140167
P-31	Parking	136	136/140167
P-32	Parking	136	136/140167
P-33	Parking	136	136/140167
P-34	Parking	136	136/140167
P-35	Parking	136	136/140167
P-36	Parking	136	136/140167
P-37	Parking	136	136/140167
P-38	Parking	153	153/140167
P-39	Parking	153	153/140167
P-40	Parking	153	153/140167
P-41	Parking	153	153/140167
P-42	Parking	156	156/140167
P-43	Parking	156	156/140167
P-44	Parking	142	142/140167
P-45	Parking	149	149/140167
P-46	Parking	149	149/140167
P-47	Parking	149	149/140167
P-48	Parking	149	149/140167
P-49	Parking	149	149/140167
P-50	Parking	149	149/140167
P-51	Parking	153	153/140167
P-52	Parking	153	153/140167
P-53	Parking	136	136/140167
P-54	Parking	136	136/140167
P-55	Parking	145	145/140167
P-56	Parking	145	145/140167
P-57	Parking	145	145/140167
P-58	Parking	145	145/140167
P-59	Parking	145	145/140167
P-60	Parking	145	145/140167
P-61	Parking	136	136/140167
P-62	Parking	148.2	148.2/140167
P-63	Parking	153	153/140167
P-64	Parking	145	145/140167
P-65	Parking	136	136/140167
P-66	Parking	136	136/140167
P-67	Parking	136	136/140167
P-68	Parking	136	136/140167
P-69	Parking	136	136/140167
P-70	Parking	136	136/140167
P-71	Parking	136	136/140167

<u>Unit</u>	<u>Unit Type</u>	<u>Square Footage</u>	<u>Undivided Interest</u>
P-72	Parking	136	136/140167
P-73	Parking	136	136/140167
P-74	Parking	136	136/140167
P-75	Parking	153	153/140167
P-76	Parking	153	153/140167
P-77	Parking	153	153/140167
P-78	Parking	154	154/140167
P-79	Parking	154	154/140167
P-80	Parking	154	154/140167
P-81	Parking	154	154/140167
P-82	Parking	142	142/140167
P-83	Parking	149	149/140167
P-84	Parking	149	149/140167
P-85	Parking	149	149/140167
P-86	Parking	149	149/140167
P-87	Parking	149	149/140167
P-88	Parking	149	149/140167
P-89	Parking	149	149/140167
P-90	Parking	149	149/140167
P-91	Parking	136	136/140167
P-92	Parking	136	136/140167
P-93	Parking	145	145/140167
P-94	Parking	145	145/140167
P-95	Parking	145	145/140167
P-96	Parking	145	145/140167
P-97	Parking	145	145/140167
P-98	Parking	145	145/140167
P-99	Parking	136	136/140167
P-100	Parking	136	136/140167
P-101	Parking	136	136/140167
P-102	Parking	148	148/140167
P-103	Parking	136	136/140167
P-104	Parking	145	145/140167
P-105	Parking	136	136/140167
P-106	Parking	136	136/140167
P-107	Parking	136	136/140167
P-108	Parking	136	136/140167
P-109	Parking	136	136/140167
P-110	Parking	136	136/140167
P-111	Parking	136	136/140167
P-112	Parking	136	136/140167
P-113	Parking	136	136/140167
P-114	Parking	136	136/140167
P-115	Parking	156	156/140167

<u>Unit</u>	<u>Unit Type</u>	<u>Square Footage</u>	<u>Undivided Interest</u>
P-116	Parking	156	156/140167
P-117	Parking	156	156/140167
P-118	Parking	156	156/140167
P-119	Parking	156	156/140167
P-120	Parking	156	156/140167
P-121	Parking	156	156/140167
P-122	Parking	136	136/140167
P-123	Parking	150	150/140167
P-124	Parking	150	150/140167
P-125	Parking	150	150/140167
P-126	Parking	150	150/140167
P-127	Parking	150	150/140167
P-128	Parking	150	150/140167
P-129	Parking	150	150/140167
P-130	Parking	150	150/140167
P-131	Parking	136	136/140167
P-132	Parking	136	136/140167
P-133	Parking	145	145/140167
P-134	Parking	144	144/140167
P-135	Parking	145	145/140167
P-136	Parking	144	144/140167
P-137	Parking	145	145/140167
P-138	Parking	140	140/140167
P-139	Parking	136	136/140167
P-140	Parking	136	136/140167
P-141	Parking	136	136/140167
P-142	Parking	136	136/140167
P-143	Parking	147	147/140167
P-144	Parking	153	153/140167
P-145	Parking	153	153/140167
P-146	Parking	136	136/140167
P-147	Parking	136	136/140167
P-148	Parking	136	136/140167
P-149	Parking	136	136/140167
P-150	Parking	136	136/140167
P-151	Parking	136	136/140167
P-152	Parking	136	136/140167
P-153	Parking	136	136/140167
S-1	Storage	67	67/140167
S-2	Storage	57	57/140167
S-3	Storage	112	112/140167
S-4	Storage	60	60/140167
S-5	Storage	74	74/140167
S-6	Storage	14	14/140167

<u>Unit</u>	<u>Unit Type</u>	<u>Square Footage</u>	<u>Undivided Interest</u>
S-7	Storage	19	19/140167
S-8	Storage	17	17/140167
S-9	Storage	53.4	53.4/140167
S-10	Storage	18	18/140167
S-11	Storage	12	12/140167
S-12	Storage	12	12/140167
S-13	Storage	12	12/140167
S-14	Storage	12	12/140167
S-15	Storage	12	12/140167
S-16	Storage	12	12/140167
S-17	Storage	18	18/140167
S-18	Storage	18	18/140167
S-19	Storage	12	12/140167
S-20	Storage	12	12/140167
S-21	Storage	16	16/140167
S-22	Storage	26	26/140167
S-23	Storage	16	16/140167
S-24	Storage	17	17/140167
S-25	Storage	17	17/140167
S-26	Storage	17	17/140167
S-27	Storage	17	17/140167
S-28	Storage	22	22/140167
S-29	Storage	17	17/140167
S-30	Storage	17	17/140167
S-31	Storage	17	17/140167
S-32	Storage	17	17/140167
S-33	Storage	22	22/140167
S-34	Storage	14	14/140167
S-35	Storage	19	19/140167
S-36	Storage	17	17/140167
S-37	Storage	53	53/140167
S-38	Storage	18	18/140167
S-39	Storage	12	12/140167
S-40	Storage	12	12/140167
S-41	Storage	12	12/140167
S-42	Storage	12	12/140167
S-43	Storage	12	12/140167
S-44	Storage	12	12/140167
S-45	Storage	18	18/140167
S-46	Storage	18	18/140167
S-47	Storage	12	12/140167
S-48	Storage	12	12/140167
S-49	Storage	16	16/140167
S-50	Storage	26	26/140167

<u>Unit</u>	<u>Unit Type</u>	<u>Square Footage</u>	<u>Undivided Interest</u>
S-51	Storage	17	17/140167
S-52	Storage	17	17/140167
S-53	Storage	17	17/140167
S-54	Storage	17	17/140167
S-55	Storage	17	17/140167
S-56	Storage	22	22/140167
S-57	Storage	17	17/140167
S-58	Storage	17	17/140167
S-59	Storage	17	17/140167
S-60	Storage	17	17/140167
S-61	Storage	22	22/140167
S-62	Storage	14	14/140167
S-63	Storage	22	22/140167
S-64	Storage	17	17/140167
S-65	Storage	15	15/140167
S-66	Storage	12	12/140167
S-67	Storage	12	12/140167
S-68	Storage	12	12/140167
S-69	Storage	12	12/140167
S-70	Storage	27	27/140167
S-71	Storage	18	18/140167
S-72	Storage	12	12/140167
S-73	Storage	12	12/140167
S-74	Storage	12	12/140167
S-75	Storage	12	12/140167
S-76	Storage	12	12/140167
S-77	Storage	12	12/140167
S-78	Storage	18	18/140167
S-79	Storage	18	18/140167
S-80	Storage	12	12/140167
S-81	Storage	12	12/140167
S-82	Storage	16	16/140167
S-83	Storage	26	26/140167
S-84	Storage	17	17/140167
S-85	Storage	17	17/140167
S-86	Storage	17	17/140167
S-87	Storage	17	17/140167
S-88	Storage	17	17/140167
S-89	Storage	22	22/140167
S-90	Storage	17	17/140167
S-91	Storage	17	17/140167
S-92	Storage	17	17/140167
S-93	Storage	17	17/140167
S-94	Storage	22	22/140167

<u>Unit</u>	<u>Unit Type</u>	<u>Square Footage</u>	<u>Undivided Interest</u>
S-95	Storage	54	54/140167
S-96	Storage	12.4	12.4/140167
S-97	Storage	11.8	11.8/140167
S-98	Storage	11.8	11.8/140167
S-99	Storage	13.4	13.4/140167
S-100	Storage	12	12/140167
S-101	Storage	14	14/140167
S-102	Storage	14	14/140167
S-103	Storage	12	12/140167
S-104	Storage	13	13/140167
S-105	Storage	21	21/140167
S-106	Storage	17	17/140167
S-107	Storage	25	25/140167
S-108	Storage	57	57/140167
TOTAL		140,167.00	

EXHIBIT C

BYLAWS

OF

BENSON TOWER CONDOMINIUM OWNERS ASSOCIATION

TABLE OF CONTENTS

		Page
ARTICLE 1	PLAN OF CONDOMINIUM OWNERSHIP	1
1.1	Name and Location	1
1.2	Principal Office	1
1.3	Purposes	1
1.4	Applicability of Bylaws	1
1.5	Composition of Association.....	1
1.6	Incorporation.....	1
1.7	Definitions	1
ARTICLE 2	MEETINGS OF ASSOCIATION	1
2.1	Place of Meetings	1
2.2	Organizational and Turnover Meeting	2
2.3	Annual Meetings	2
2.4	Special Meetings	2
2.5	Notice of Meetings	2
2.6	Voting	2
2.7	Absentee Ballots and Proxies.....	3
2.8	Fiduciaries and Joint Owners.....	3
2.9	Tenants and Contract Vendors.....	3
2.10	Quorum of Unit Owners	3
2.11	Majority Vote.....	4
2.12	Order of Business	4
2.13	Rules of Order.....	4
2.14	Ballot Meetings	4
ARTICLE 3	BOARD OF DIRECTORS	5
3.1	Number and Qualification	5
3.2	Interim Directors	6
3.3	Transitional Committee	6
3.4	Election and Term of Office	6
3.5	Vacancies	6
3.6	Removal of Directors	6

3.7	Powers and Duties	7
3.8	Managing Agent or Manager	9
3.9	Contracts Entered into by Declarant or Interim Board.....	9
3.10	Organizational Meeting	10
3.11	Regular and Special Meetings.....	10
3.12	Open Meetings	10
3.13	Waiver of Notice	11
3.14	Quorum of Board of Directors.....	11
3.15	Compensation.....	11
3.16	Liability and Indemnification of Directors, Officers and Manager.	11
3.17	Insurance.....	12
ARTICLE 4	OFFICERS	12
4.1	Designation	12
4.2	Election of Officers	12
4.3	Removal of Officers	12
4.4	Chairperson	12
4.5	Secretary	12
4.6	Treasurer	13
4.7	Execution of Instruments.....	13
4.8	Compensation of Officers.....	13
ARTICLE 5	BUDGET, EXPENSES AND ASSESSMENTS	13
5.1	Budget.....	13
5.2	Determination of Common Expenses.....	13
5.3	Assessment of Common Expenses.....	15
	(a) Obligation to pay.	15
	(b) Working capital fund.	15
	(c) Commencement of regular operating expense assessments.....	16
	(d) Commencement of assessment for replacement reserves.	16
5.4	Special or Extraordinary Assessments	16
	(a) Special Assessments for Capital Improvements.....	16
	(b) Other Special or Extraordinary Assessments.	16
5.5	Replacement Reserves.....	16
	(a) Establishment of Account.	16

	(b) Funding of Account	17
	(c) Reserve Studies.....	17
	(d) Use of Reserve Funds.	17
	(e) Sale of Units.	18
5.6	Default in Payment of Assessments	18
5.7	Foreclosure of Liens for Unpaid Assessments.....	18
5.8	Statement of Assessments.....	18
5.9	Priority of Lien; First Mortgages	19
5.10	Voluntary Conveyance	19
ARTICLE 6	RECORDS AND AUDITS	19
6.1	General Records	19
6.2	Financial Records and Accounts.....	19
6.3	Assessment Roll	20
6.4	Payment of Vouchers	20
6.5	Reports and Audits	20
6.6	Notice of Sale, Mortgage, Rental or Lease.....	20
6.7	Availability of Records.....	20
6.8	Statement of Assessments Due	21
ARTICLE 7	MAINTENANCE AND USE OF CONDOMINIUM PROPERTY	21
7.1	Maintenance and Repair	21
	(a) Units.	21
	(b) Common elements.	21
	(c) Repairs.....	21
7.2	Additions, Alterations or Improvements	22
7.3	Damage or Destruction by Casualty of Condominium Property	22
7.4	Condemnation	23
	(a) Complete Taking.	23
	(b) Partial Taking.	24
7.5	Restrictions and Requirements Respecting Use of Condominium Property.....	24
	(a) Residential use.....	24
	(b) Use of common elements.	24
	(c) Offensive or unlawful activities.	24
	(d) Animals	25

(e)	Exterior lighting or noisemaking devices and antennas.....	25
(f)	Windows, decks, and outside walls.	25
(g)	Signs.....	25
(h)	Trash.....	25
(i)	Insurance.	26
(j)	Water beds.....	26
(k)	Washing Machines.....	26
(l)	Association rules and regulations.	26
7.6	Leasing and Rental of Units.....	26
7.7	Failure to Follow Maintenance Manual.....	27
(a)	Association.	27
(b)	Unit Owners.	28
7.8	Abatement and Enjoining of Violations.....	28
ARTICLE 8	INSURANCE.....	29
8.1	Types of Insurance.....	29
(a)	Property Damage Insurance.	29
(b)	Liability Insurance.	29
(c)	Workers' Compensation Insurance.	30
(d)	Fidelity Insurance.	30
(e)	Directors' and Officers' Liability Insurance.	30
(f)	Insurance by Unit Owners.....	30
8.2	Other Insurance Requirements.....	31
8.3	Optional Provisions.....	32
8.4	FannieMae and GNMA Requirements.....	32
ARTICLE 9	AMENDMENTS TO BYLAWS.....	33
9.1	How Proposed.....	33
9.2	Adoption.....	33
9.3	Execution and Recording.....	33
ARTICLE 10	DISPUTE RESOLUTION.....	34
10.1	Claims Other than for Defective or Negligent Construction.	34
(a)	Mediation.	34
(b)	Arbitration.	35
(c)	Excluded Matters.....	35

(d)	Costs and Attorneys' Fees.	35
10.2	Claims for Negligent or Defective Construction.	35
(a)	Initial Dispute Resolution Procedures.	36
(b)	Mediation.	36
(c)	Arbitration.	37
(d)	Third Parties.	37
(e)	Attorney Fees.	37
(f)	Confidentiality.	37
(g)	Time Periods within which Claims must be Asserted.	37
10.3	Arbitration.....	38
(a)	Selection of Arbitrator	38
(b)	Consolidated Arbitration.....	38
(c)	Discovery	38
(d)	Evidence.....	38
10.4	Survival.	39
ARTICLE 11	MISCELLANEOUS.....	39
11.1	Notices	39
11.2	Waiver	39
11.3	Action Without a Meeting	39
11.4	Invalidity; Number; Captions	39
11.5	Conflicts.....	39

BYLAWS OF
BENSON TOWER CONDOMINIUM OWNERS ASSOCIATION

Article 1

PLAN OF CONDOMINIUM OWNERSHIP

1.1 **Name and Location.** These are the bylaws of the **BENSON TOWER CONDOMINIUM OWNERS ASSOCIATION** (the “**Association**”). **BENSON TOWER CONDOMINIUM** (the “**Condominium**”) is located in the City of Portland, Multnomah County, Oregon, and has been submitted to the Oregon Condominium Act by a declaration recorded simultaneously with these Bylaws (the “**Declaration**”). The location of the Condominium is more specifically described in the Declaration.

1.2 **Principal Office.** The principal office of the Association shall be located at such address as may be designated by the board of directors from time to time.

1.3 **Purposes.** This Association is formed under the provisions of the Oregon Condominium Act to serve as the means through which the unit owners may take action with regard to the administration, management and operation of the Condominium.

1.4 **Applicability of Bylaws.** The Association, all unit owners, and all persons using the Condominium property shall be subject to these Bylaws and to all rules and regulations that may be adopted pursuant to these Bylaws.

1.5 **Composition of Association.** The Association shall be composed of all the unit owners of the Condominium, including The Benson Tower, LLC, an Oregon limited liability company, and its successors and assigns (the “**Declarant**”), and the Association, itself, to the extent any of these own any unit or units of the Condominium.

1.6 **Incorporation.** The Association shall be incorporated under the Oregon Non-Profit Corporation Law. The Articles of Incorporation of the Association shall be consistent with the Declaration and these Bylaws, and these Bylaws shall constitute the bylaws of the incorporated association.

1.7 **Definitions.** The definitions contained in or adopted by the Declaration shall be applicable to these Bylaws.

Article 2

MEETINGS OF ASSOCIATION

2.1 **Place of Meetings.** The Association shall hold meetings at such suitable place convenient to the unit owners as may be designated by the board of directors from time to time.

2.2 **Organizational and Turnover Meeting.** Within three years after the date of conveyance of the first unit to a person other than a successor declarant, or within ninety (90) days after Declarant has sold and conveyed to a person other than a successor declarant seventy-five percent (75%) or more of the units in the Condominium, whichever is earlier, the Declarant shall call the first meeting of the unit owners to organize the Association and to elect directors. Notice of such meeting shall be given to all owners as provided in Section 2.5. If Declarant fails to call the meeting, the meeting may be called and notice given by any unit owner or Mortgagee of a unit. The expense of giving notice shall be paid or reimbursed by the Association. At the meeting, Declarant shall deliver to the Association such information and documents as may be required by the Oregon Condominium Act. Nothing in this Section shall be construed as preventing the Declarant from calling the organizational and turnover meeting prior to such date, or from calling informal, informational meetings of the unit owners.

2.3 **Annual Meetings.** The annual meetings of the Association shall be held on such date each year as may be established by the board of directors from time to time, or if the board does not establish such a date, then in the month of February at such hour and on such date as the chairperson may designate, or if the chairperson should fail to designate such date by the first day of February then on the last Tuesday in February. The annual meetings shall be for the purpose of electing directors and for the transaction of such other business as may properly come before the meeting.

2.4 **Special Meetings.** Special meetings of the Association may be called by the chairperson or by a majority of the board of directors, and must be called by such officers upon receipt of a written request from unit owners owning at least thirty percent (30%) of the voting rights stating the purpose of the meeting. Business transacted at a special meeting shall be confined to the purposes stated in the notice of meeting.

2.5 **Notice of Meetings.** Notice of the annual meeting and all other meetings of the Association stating the time and place and the purpose or purposes for which the meeting is being called shall be given by the chairperson or secretary. Such notice shall be in writing and mailed not less than ten (10) days nor more than fifty (50) days prior to the date of the meeting to each unit owner at his or her address as it appears on the books of the Association and to any first Mortgagee requesting such notice. Proof of such mailing shall be given by the affidavit of the person giving the notice. For a period of ten (10) years following recording of the Declaration, notices of meetings (including agendas) shall also be given to Declarant in the same manner as given to unit owners, and Declarant or a representative of Declarant shall be entitled to attend such meetings. Notice of meeting may be waived by any unit owner before or after meetings. When a meeting is adjourned for less than thirty (30) days, no notice of the adjourned meeting need be given other than by announcement at the meeting at which such adjournment takes place.

2.6 **Voting.** Each owner of a Living Unit shall have one vote for each Living Unit of the Condominium owned by such unit owner; provided, however, that Declarant shall have five votes for each such unit owned by Declarant until the earlier of (a) when Declarant has sold and conveyed to a person other than a successor declarant 75 percent or more of the Living Units in the Condominium, or (b) three years after the date of the first conveyance of a unit to a person

other than a successor declarant. No voting rights shall attach to Parking Units or Storage Units. The Declarant shall be entitled to vote as the unit owner of any then existing Living Units retained by the Declarant, and the board of directors shall be entitled to vote on behalf of any Living Unit that has been acquired by or on behalf of the Association; provided, however, that the board of directors shall not be entitled to vote such units in any election of directors.

2.7 **Absentee Ballots and Proxies.** A vote may be cast in person, by absentee ballot or by proxy. A proxy given by a unit owner to any person who represents such owner at meetings of the Association shall be in writing and signed by such owner, and shall be filed with the secretary at any time prior to or at the start of the meeting. An owner may not revoke a proxy given pursuant to this Section except by actual notice of revocation to the person presiding over a meeting or to the board of directors if a vote is being conducted by written ballot in lieu of a meeting. A proxy shall not be valid if it is undated or purports to be revocable without notice. A proxy shall terminate one year after its date unless the proxy specifies a shorter term. Every proxy shall automatically cease upon sale of the unit by its owner. A unit owner may pledge or assign such owner's voting rights to a Mortgagee. In such a case, the Mortgagee or its designated representative shall be entitled to receive all notices to which the unit owner is entitled under these Bylaws and to exercise the unit owner's voting rights from and after the time that the Mortgagee shall give written notice of such pledge or assignment to the board of directors. Any first Mortgagee may designate a representative to attend all or any meetings of the Association.

2.8 **Fiduciaries and Joint Owners.** An executor, administrator, guardian or trustee may vote, in person or by proxy, at any meeting of the Association with respect to any unit owned or held in such capacity, whether or not the same shall have been transferred to his or her name; provided, that such person shall satisfy the secretary that he or she is the executor, administrator, guardian or trustee, holding such unit in such capacity. Whenever any unit is owned by two or more persons jointly, according to the records of the Association, the vote or proxy of such unit may be exercised by any one of the owners then present, in the absence of protest by a co-owner. In the event of disagreement among the co-owners, the vote of such unit shall be disregarded completely in determining the proportion of votes given with respect to such matter unless a valid court order establishes the authority of a co-owner to vote.

2.9 **Tenants and Contract Vendors.** Unless otherwise expressly stated in the rental agreement or lease, all voting rights allocated to a unit shall be exercised by the owner/landlord. Unless otherwise stated in the contract, all voting rights allocated to a unit shall be exercised by the vendee of any recorded land sale contract on the unit.

2.10 **Quorum of Unit Owners.** At any meeting of the Association, members holding twenty percent (20%) of the voting rights, present in person or by proxy, shall constitute a quorum. The subsequent joinder of a unit owner in the action taken at a meeting by signing and concurring in the minutes of the meeting shall constitute the presence of such person for the purpose of determining a quorum. When a quorum is once present to organize a meeting, it cannot be broken by the subsequent withdrawal of a unit owner or owners. If any meeting of members cannot be organized because of a lack of quorum, the members who are present, either in person or by proxy, may adjourn the meeting from time to time until a quorum is present. The

quorum for the adjourned meeting shall be reduced to ten percent (10%) of the voting rights, present in person or by proxy.

2.11 **Majority Vote**. The vote of the holders of more than fifty percent (50%) of the voting rights, present in person or by proxy at a meeting at which a quorum is constituted, shall be binding upon all unit owners for all purposes except where a higher percentage vote is required by law, by the Declaration or by these Bylaws.

2.12 **Order of Business**. The order of business at annual meetings of the Association shall be:

- (a) Calling of the roll and certifying of proxies;
- (b) Proof of notice of meeting or waiver of notice;
- (c) Reading of minutes of preceding meeting;
- (d) Reports of officers;
- (e) Reports of committees, if any;
- (f) Election of directors;
- (g) Unfinished business;
- (h) New business; and
- (i) Adjournment.

2.13 **Rules of Order**. Unless other rules of order are adopted by resolution of the Association or the board of directors, all meetings of the Association shall be conducted according to the latest edition of *Robert's Rules of Order* published by Robert's Rules Association.

2.14 **Ballot Meetings**.

(a) At the discretion of the board of directors, any action that may be taken at any annual, regular or special meeting of the Association may be taken without a meeting if the Association delivers a written ballot to every member that is entitled to vote on the matter; provided, however, that a ballot meeting may not substitute for the organizational and turnover meeting described in Section 2.2 or, if a majority of the units are the principal residences of the occupants, for the annual meetings of the Association. The written ballot shall set forth each proposed action and provide an opportunity to vote for or against each proposed action.

(b) The board of directors shall provide owners with at least ten (10) days' notice before written ballots are mailed or otherwise delivered. If, at least three (3) days before written ballots are scheduled to be mailed or otherwise distributed, at least ten percent (10%) of

the owners petition the board of directors requesting secrecy procedures, a written ballot must be accompanied by a secrecy envelope, a return identification envelope to be signed by the owner and instructions for marking and returning the ballot. The notice shall state the general subject matter of the vote, the right of the owners to request secrecy procedures, the date after which ballots may be distributed, the date and time by which any petition must be received by the board requesting secrecy procedures and the address where any petition must be received. Notwithstanding the applicable provisions of paragraph (c) of this Section, written ballots that are returned in secrecy envelopes may not be examined or counted before the deadline for returning ballots has passed.

(c) If approval of a proposed action would otherwise require a meeting at which a certain quorum must be present and at which a certain percentage of total votes cast is required to authorize the action, the proposal will be deemed to be approved when the date for return of ballots has passed, a quorum of unit owners has voted and the required percentage of approving votes has been received. Otherwise, the proposal shall be deemed to be rejected. If approval of a proposed action otherwise would require a meeting at which a specified percentage of unit owners must authorize the action, the proposal shall be deemed to be approved when the percentage of total votes cast in favor of the proposal equals or exceeds such required percentage. The proposal shall be deemed to be rejected when the number of votes cast in opposition renders approval impossible or when both the date for return of ballots has passed and such required percentage has not been met. Except as otherwise provided in paragraph (b) of this Section, votes may be counted from time to time before the final return date to determine whether the proposal has passed or failed by the votes already cast on the date they are entered.

(d) All solicitations for votes by written ballot shall state the number of responses needed to meet any applicable quorum requirement and the total percentage of votes needed for approval. All such solicitations for votes shall specify the period during which the Association will accept written ballots for counting, which period shall end on the earliest of (i) the date on which the Association has received a sufficient number of approving ballots to pass the proposal, or (ii) the date on which the Association has received a sufficient number of disapproving ballots to render the proposal impossible of passage, or (iii) a date certain on which all ballots must be returned to be counted. A written ballot may not be revoked.

Article 3

BOARD OF DIRECTORS

3.1 **Number and Qualification.** The affairs of the Association shall be governed by a board of directors composed of one (1) to three (3) interim directors or five (5) regular directors, as provided in Sections 3.2 and 3.4 of this Article. All directors, other than interim directors appointed by Declarant, shall be owners or co-owners of units of the Condominium. For purposes of this Section, the officers members, managers, partners and any duly appointed employees of any corporation, limited liability company or partnership shall be considered co-owners of any units owned by such corporation, limited liability company or partnership.

3.2 **Interim Directors.** Upon the recording of the Declaration submitting the Condominium to the Oregon Condominium Act the Declarant shall appoint an interim board of one (1) to three (3) directors, who shall serve until replaced by Declarant or their successors have been elected by the unit owners as provided below.

3.3 **Transitional Committee.** Unless the organizational and turnover meeting described in Section 2.2 above has already been held, Declarant shall call a meeting of the unit owners for the purpose of forming a transitional committee. The meeting shall be called within sixty (60) days of conveyance to persons other than Declarant of fifty percent (50%) of the units. Declarant shall give notice of the meeting as provided in Section 2.5 above. The committee shall consist of two or more members elected by the unit owners other than Declarant and not more than one representative of Declarant. The members shall serve until the organizational and turnover meeting. The transitional committee shall be advisory only and its purpose shall be to enable ease of transition from control of the administration of the Association by the Declarant to control by the unit owners. The committee shall have access to the information, documents and records that Declarant must turn over to the unit owners at the time of the organizational and turnover meeting. If Declarant fails to call the meeting to elect a transitional committee within the time specified, the meeting may be called and notice given by any unit owner.

3.4 **Election and Term of Office.** At the first organizational and turnover meeting called by Declarant pursuant to Section 2.2 of these Bylaws, the interim directors shall resign and five (5) successors shall be elected, two (2) to serve until the next annual meeting and three (3) to serve until the second annual meeting after their election. The candidates receiving the greatest number of votes shall be elected to the two-year terms. Thereafter, at the expiration of the initial term of office of each respective director, his or her successor shall be elected to serve for a term of two (2) years, so that the term of not less than one-third of the directors shall expire annually. Directors shall hold office until their respective successors have been elected by the unit owners. Election shall be by plurality. Upon a majority vote of the membership present in person or by proxy at a meeting called for such purpose, the number of directors may be increased to seven (7) directors. Upon such increase, two additional directors shall be elected, one to serve until the next annual meeting and the other to serve until the second annual meeting after their election. Thereafter, each successor shall be elected to serve for a two-year term.

3.5 **Vacancies.** Vacancies in the board of directors caused by any reason other than the removal of a director by a vote of the Association shall be filled by vote of the majority of the remaining directors, even though they may constitute less than a quorum, or by a sole remaining director. Each person so elected shall be a director until a successor is elected to fill the unexpired term at the next annual meeting of the Association or the next special meeting of the Association called for that purpose. Vacancies in interim directors shall be filled by Declarant.

3.6 **Removal of Directors.** At any regular or special meeting of the Association duly called, any one or more of the directors, other than interim directors, may be removed with or without cause by a majority vote of the unit owners present in person or by proxy, and a successor shall be elected at that meeting to fill the vacancy thus created. The notice of any such meeting shall state that such removal is to be considered, and any director whose removal has been proposed shall be given an opportunity to be heard at that meeting.

3.7 **Powers and Duties.** The board of directors shall have all of the powers and duties necessary for the administration of the affairs of the Association, except such powers and duties as by law or by the Declaration or by these Bylaws may not be delegated to the board of directors by the unit owners; provided, however, that the board of directors may not take any action that could unreasonably interfere with the sale, lease or other disposition of units owned by Declarant or that could abridge, modify, eliminate or otherwise affect any right, power, easement, privilege or benefit reserved for Declarant or which would impose any discriminatory charge or fee against Declarant, without the prior written consent of Declarant. The powers and duties to be exercised by the board of directors shall include, but shall not be limited to the following:

(a) Operation, care, upkeep, maintenance, repair and replacement of the general and limited common elements and Association property.

(b) Determination of the amounts required for operation, maintenance and other affairs of the Association, and the making of such expenditures.

(c) Preparation and adoption of budgets, preparation, review and update of reserve studies and assessment and collection of the common expenses, all in accordance with the provisions of these Bylaws.

(d) Employment and dismissal of such personnel as necessary for the efficient maintenance, upkeep and repair of the common elements.

(e) Employment of legal, accounting or other personnel for reasonable compensation to perform such services as may be required for the proper administration of the Association; provided, however, the board may not incur or commit the Association to incur legal fees in excess of \$5,000 for any specific litigation or claim matter or enter into any contingent fee contract on any claim in excess of \$100,000 unless the unit owners have enacted a resolution authorizing the incurring of such fees or contract by a vote of seventy-five percent (75%) of the total voting rights of the Association. These limitations shall not be applicable to legal fees incurred in defending the Association and the board of directors from claims or litigation brought against them. The limitations set forth in this paragraph shall increase by ten percent on each fifth anniversary of the recording of the Declaration. To the extent required by ORS 100.490, the board shall notify the owners prior to instituting litigation or administrative proceedings. With regard to any pending litigation involving the Association, the board shall periodically report to the unit owners as to the status (including settlement offers), progress, and method of funding such litigation. Nothing in this paragraph shall be construed as requiring the board to disclose any privileged communication between the Association and its counsel.

(f) Opening of bank accounts on behalf of the Association and designating the signatories required therefor.

(g) Preparation and distribution of annual financial statements in accordance with these Bylaws and annual preparation and filing of all required income tax returns or forms for the Association.

(h) Borrowing money on behalf of the Association when required in connection with the operation, care, upkeep, and maintenance of the common elements and Association property; provided, however, that (i) the consent of the unit owners shall be required for the borrowing of any sum in excess of an amount or amounts, aggregated for the calendar year in question, exceeding fifteen percent (15%) of the estimated budget of the Association for that calendar year to cover the operation, care upkeep and maintenance of the common elements, and (ii) no lien to secure repayment of any sum borrowed may be created on any unit or its appurtenant interest in the common elements without the consent of the owner of such unit. If any sum borrowed by the board of directors on behalf of the Association pursuant to the authority contained in this paragraph is not repaid by the Association, a unit owner who pays to the creditor such proportion thereof equal to his interest in the common elements shall be entitled to obtain from the creditor a release of any judgment or other lien which the creditor shall have filed or shall have the right to file against such owner's unit.

(i) Purchasing units of the Condominium at foreclosure or other judicial sales in the name of the Association, or its designee, on behalf of all the unit owners as provided in these Bylaws, and selling, leasing, mortgaging, voting the votes appurtenant to (other than for the election of directors), or otherwise dealing with units of the Condominium acquired by the Association or its designee on behalf of all the unit owners.

(j) Obtaining insurance or bonds pursuant to the provisions of these Bylaws and at least annually reviewing the insurance coverage of the Association.

(k) Making additions and improvements to, or alterations of, the common elements; provided, however, that no such project may be undertaken by the board if the total cost will exceed the amount of \$20,000 unless the unit owners have enacted a resolution authorizing the project by a majority vote of the members, except that no such vote shall be required for work that is urgently needed for life, safety or structural integrity reasons. This limitation shall not be applicable to maintenance, repairs or replacement undertaken pursuant to paragraph (a) above. The limitation set forth in this paragraph shall increase by \$1,000 on each anniversary of the recording of the Declaration.

(l) Modify, close, remove, eliminate or discontinue the use of a general common element facility or improvement or portion of the common element landscaping, except that modification, closure, removal, elimination or discontinuance other than on a temporary basis of any swimming pool, spa or recreation or community building must be approved by at least a majority of the unit owners voting on such matter at a meeting or by written ballot held or conducted in accordance with these Bylaws.

(m) Designating one or more committees which, to the extent provided in the resolution designating the committee, shall have the powers of the board of directors in the management of the affairs of the Association. At least one member of each committee shall be a member of the board of directors.

(n) Enforcement by legal means of the provisions of the Oregon Condominium Act, the Declaration, these Bylaws and any rules and regulations adopted

hereunder. Nothing in these Bylaws shall be construed as requiring the Association to take any specific action to enforce violations.

(o) Maintain a current mailing address for the Association, file an Annual Report and any amendment in accordance with ORS 100.250, and maintain and keep current the information required to enable the Association to comply with ORS 100.480(7).

(p) Subject to the restrictions in subsection (e) above, initiate or intervene in litigation or administrative proceedings (including mediation under Article 10 of these Bylaws) in the name of the Association, and without joining the individual unit owners, as permitted under ORS 100.405(4)(e) and (11); provided that no litigation or administrative proceeding may be initiated on a matter relating to or affecting the unit or interest of a unit owner unless the unit owner has consented in writing to such action after full disclosure of the potential cost, duration and outcomes of the proposed litigation or administrative proceeding.

(q) Establish, periodically update, and implement a Maintenance Manual that identifies those components of the common elements requiring periodic maintenance, including a maintenance manual defining how and when such maintenance should be performed and setting forth the estimated cost of such maintenance. The Maintenance Manual shall provide for not less than annual inspections of the property for evidence of water intrusion or other needed repairs by a knowledgeable independent party, and the board shall reasonably address any matters revealed by the inspection. For a period of ten (10) years following recording of the Declaration, Declarant shall be notified prior to the inspections, shall have a right for Declarant or its employees or contractors to be present during the inspections and have a right to receive a copy of the inspection reports. The operating and reserve budgets of the Association shall take into account the costs of complying with the Maintenance Manual. Changes or updates to the Maintenance Manual should be based upon the advice of competent experts or consultants.

3.8 **Managing Agent or Manager.** On behalf of the Association, the board of directors may employ or contract for a managing agent or a manager at a compensation to be established by the board of directors. The board of directors may delegate to the managing agent or manager such duties and powers as the board of directors may authorize. In the absence of such appointment, the board of directors shall act as manager; provided, however, that the board of directors may not terminate professional management and assume self-management unless the decision to do so is approved by at least seventy-five percent (75%) of the total voting rights of the Association.

3.9 **Contracts Entered into by Declarant or Interim Board.** Notwithstanding any other provision of these Bylaws, any management contracts, service contracts or employment contracts entered into by the Declarant or the interim board on behalf of the Association shall have a term not in excess of three years. In addition, any such contract shall provide that it may be terminated without cause or penalty by the Association or board of directors upon not less than thirty (30) days' notice to the other party given not later than sixty (60) days after election of the permanent board at the organizational and turnover meeting described in Section 2.2 of these Bylaws.

3.10 **Organizational Meeting.** Unless otherwise agreed by the board, within fourteen (14) days following the annual meeting of the Association or following any meeting at which an election of directors has been held, the board of directors shall hold an organization meeting at such place and time as shall have been fixed by the directors at the meeting at which the election was held.

3.11 **Regular and Special Meetings.** Regular meetings of the board of directors may be held at such time and place as shall be determined, from time to time, by a majority of the directors. Special meetings of the board of directors may be called by the chairperson and must be called by the secretary at the written request of at least two directors. Notice of any special meeting shall be given to each director, personally or by mail, telephone or telegraph at least seven (7) days prior to the day named for such meeting, and shall state the time, place and purpose of such meeting. For a period of ten (10) years following recording of the Declaration, notices of meetings (including agendas) shall also be given to Declarant in the same manner as given to Directors. Unless other rules of order are adopted by resolution of the Association or the board of directors, all meetings of the board of directors shall be conducted according to the latest edition of *Robert's Rules of Order* published by Robert's Rules Association.

3.12 **Open Meetings.**

(a) All meetings of the board of directors shall be open to unit owners and, for a period of ten (10) years following recording of the Declaration, to Declarant or a representative of Declarant, except that, in the discretion of the board, the following matters may be considered in executive session: (i) consultation with legal counsel concerning the rights and duties of the Association regarding existing or potential litigation, or criminal matters; (ii) personnel matters, including salary negotiations and employee discipline; (iii) negotiation of contracts with third parties; and (iv) collection of unpaid assessments. Except in the case of an emergency, the board of directors shall vote in an open meeting whether to meet in executive session. If the board of directors votes to meet in executive session, the presiding officer shall state the general nature of the action to be considered, as precisely as possible, when and under what circumstances the deliberations can be disclosed to owners. The statement, motion or decision to meet in the executive session shall be included in the minutes of the meeting, and any contract or action considered in executive session shall not become effective unless the board, following the executive session, reconvenes in open meeting and votes on the contract or action, which shall be reasonably identified in the open meeting and included in the minutes.

(b) Meetings of the board of directors may be conducted by telephonic communication or by other means of communication that allows all members of the board participating to hear each other simultaneously or otherwise to be able to communicate during the meeting, except that if a majority of the units are principal residences of the occupants, then: (i) for other than emergency meetings, notice of each board of directors' meeting shall be posted at a place or places on the property at least three (3) days prior to the meeting, or notice shall be provided by a method otherwise reasonably calculated to inform the unit owners of such meeting; and (ii) only emergency meetings of the board of directors may be conducted by telephonic communication or such other means. The meeting and notice requirements of this Section may not be circumvented by chance or social meetings or by any other means.

3.13 **Waiver of Notice.** Any director may, at any time, waive notice of any meeting of the board of directors in writing, and such waiver shall be deemed equivalent to the giving of such notice. Attendance by a director at any meeting of the board shall constitute a waiver of notice by such director, except where the director attends the meeting for the express purpose of objecting to the transaction of any business because the meeting is not lawfully called or convened. If all of the directors are present at any meeting of the board, no notice to directors shall be required and any business may be transacted at such meeting.

3.14 **Quorum of Board of Directors.** At all meetings of the board of directors, a majority of the directors shall constitute a quorum for the transaction of business, and the votes of a majority of the directors present at a meeting at which a quorum is present shall constitute the decision of the board of directors. If at any meeting of the board of directors less than a quorum should be present, a majority of those present may adjourn the meeting from time to time. At any such adjourned meeting at which a quorum is present, any business that might have been transacted at the meeting originally called may be transacted without further notice to directors.

3.15 **Compensation.** No director shall receive any compensation from the Association for acting as such.

3.16 **Liability and Indemnification of Directors, Officers and Manager.** A member of the board of directors or an officer of the Association shall not be liable to the Association, any unit owner or any third party for any damage, loss or prejudice suffered or claimed on account of any action or failure to act in the performance of his or her duties so long as the individual acted in good faith, believed that the conduct was in the best interests of the Association, or at least was not opposed to its best interests, and in the case of criminal proceedings, had no reason to believe the conduct was unlawful. A director appointed under Section 3.2 of these Bylaws and Section 14.4 of the Declaration, or acting under ORS 100.200, shall not be liable to the Association, any unit owner or any third party under ORS 65.357-65.361, ORS 100.417 or associated rules of common law for any damage, loss or prejudice suffered or claimed on account of any action or failure to act that represents the exercise of authority established in Section 14.4 of the Declaration and ORS 100.200, including any action or failure to act requested by the Declarant or resulting from any prior or concurrent duty or loyalty owed by such director to the Declarant; provided that nothing in this section limits the liability of the Declarant for such actions or failure to act by a director. In the event any member of the board of directors or any officer of the Association is threatened with or made a party to any proceeding because the individual was or is a director or officer of the Association, the Association shall defend such individual against such claims and indemnify such individual against liability and expenses incurred to the maximum extent permitted by law. The manager of the Association, and its officers and employees, shall not be liable to the Association, the unit owners or any third party on account of any action or failure to act in the performance of its duties as manager, except for acts of gross negligence or intentional acts. Prior to the Organizational and Turnover Meeting described in Section 2.2, the manager shall not be liable to the Association, any unit owner or any third party for any damage, loss or prejudice suffered or claimed on account of any action or failure to act that represents the exercise of authority established in Section 14.4 of the Declaration and ORS 100.200, including any action or failure

to act requested by the Declarant or resulting from any prior or concurrent duty or loyalty owed by such director to the Declarant; provided that nothing in this section limits the liability of the Declarant for such actions or failure to act by the manager. In the event the manager is threatened with or made a party to any proceeding, the Association shall defend the manager against such claims and indemnify the manager and its officers and employees from any such claims to the maximum extent permitted by law.

3.17 **Insurance.** The board of directors shall obtain the insurance and fidelity bonds required in Article 8 of these Bylaws. In addition, the board of directors, in its discretion, may obtain such other insurance as it deems necessary to protect the interests of the Association or unit owners. The board of directors shall conduct an annual insurance review which, if appropriate, shall include an appraisal of all improvements contained in the Condominium.

Article 4

OFFICERS

4.1 **Designation.** The principal officers of the Association shall be the chairperson, the secretary and the treasurer, all of whom shall be elected by the board of directors. The directors may appoint a vice chairperson, an assistant treasurer, an assistant secretary, and such other officers as in their judgment may be necessary. The chairperson shall be a member of the board of directors, but the other officers need not be directors or unit owners.

4.2 **Election of Officers.** The officers of the Association shall be elected annually by the board of directors at the organization meeting of each new board and shall hold office at the pleasure of the board. If any office shall become vacant, the board of directors shall elect a successor to fill the unexpired term at any regular meeting of the board of directors, or at any special meeting of the board of directors called for such purpose.

4.3 **Removal of Officers.** Upon the affirmative vote of a majority of the directors, any officer may be removed either with or without cause, and a successor may be elected at any regular meeting of the board of directors, or at any special meeting of the board of directors called for such purpose.

4.4 **Chairperson.** The chairperson shall be the chief executive officer of the Association. He or she shall preside at all meetings of the Association and of the board of directors. The chairperson shall have all of the general powers and duties that are usually vested in the chief executive officer of an association, including but not limited to the power to appoint committees from among the unit owners from time to time as the chairperson may in his or her discretion decide is appropriate to assist in the conduct of the affairs of the Association.

4.5 **Secretary.** The secretary shall keep the minutes of all proceedings of the board of directors and the minutes of all meetings of the Association. He or she shall attend to the giving and serving of all notices to the unit owners and directors and other notices required by law. The secretary shall keep the records of the Association, except for those of the treasurer, and shall perform all other duties incident to the office of secretary of an association and as may

be required by the directors or the chairperson. In addition, the secretary shall act as vice chairperson, taking the place of the chairperson and performing the chairperson's duties whenever the chairperson is absent or unable to act, unless the directors have appointed another vice chairperson.

4.6 **Treasurer.** The treasurer shall have the responsibility for Association funds and securities and shall be responsible for keeping full and accurate financial records and books of account showing all receipts and disbursements, and for the preparation of required financial statements. He or she shall be responsible for overseeing the deposit of all moneys and other valuable effects in such depositories as may from time to time be designated by the board of directors, and shall disburse or cause to be disbursed funds of the Association upon properly authorized vouchers. The treasurer shall perform all other duties incident to the office of treasurer of an association and such other duties as may be assigned to him or her by the board of directors.

4.7 **Execution of Instruments.** All agreements, contracts, deeds, leases and other instruments of the Association, except checks, shall be executed by such person or persons as may be designated by general or special resolution of the board of directors and, in the absence of any general or special resolution applicable to any such instrument, then such instrument shall be signed by the chairperson. All checks shall be signed by the treasurer, or in the absence or disability of the treasurer, by the chairperson or any duly elected assistant treasurer, or by the manager.

4.8 **Compensation of Officers.** No officer who is a member of the board of directors shall receive any compensation from the Association for acting as an officer, unless such compensation is authorized by a resolution duly adopted by the unit owners. The board of directors may fix any compensation to be paid to any officers who are not also directors.

Article 5

BUDGET, EXPENSES AND ASSESSMENTS

5.1 **Budget.** The board of directors shall from time to time, and at least annually, prepare a budget for the Association, estimate the common expenses expected to be incurred, less any previous overassessment and plus any underassessment, and assess the common expenses to each unit owner in the proportion set forth in the Declaration. The budget shall provide for a reserve fund in accordance with Section 5.5 below and shall take into account the Maintenance Manual adopted pursuant to Section 3.7(q) above. Within thirty (30) days after adopting the annual budget, the board of directors shall provide a summary of the budget to all owners. If the board of directors fails to adopt an annual budget, the last adopted budget shall continue in effect.

5.2 **Determination of Common Expenses.** Common expenses shall include:

- (a) Expenses of administration, including management fees.

(b) Expenses of maintenance, repair or replacement of common elements, any other portions of the Condominium required to be maintained by the Association pursuant to the Declaration or these Bylaws, and any Association property.

(c) Cost of insurance or bonds obtained in accordance with these Bylaws.

(d) A general operating reserve, including an amount sufficient to cover the deductible under the property damage insurance policy.

(e) Reserve for replacements, repairs and maintenance.

(f) Any deficit in common expenses for any prior period.

(g) Utilities and services for the common elements and other utilities and services with a common meter or commonly billed, such as trash collection, natural gas to heat the central hot water system, water and sewer.

(h) The costs of the preparation of the annual reserve study or the renewal and update of such study.

(i) Services of any person or firm to act on behalf of the Owners in connection with any other matter where the respective interests of the Owners are deemed by the Board of Directors to be similar and nonadverse to each other.

(j) Professional management services, gardening, snow removal, waste removal (subject to the provisions of the Declaration relating thereto), painting, cleaning, outside window washing (at the election of the Board of Directors), repair and replacement of the exterior of the structures within the Condominium and maintenance, decorating, repair and replacement of the common areas of the Condominium (but not including interior surfaces of Units, and interior surfaces of doors which provide the means of ingress and egress to and from a Living Unit or Storage Unit, which the Owners shall maintain in accordance with these Bylaws), Parking Units, and such furnishings and equipment for the common areas of the Condominium as the Board of Directors shall determine are necessary and proper, which the Board of Directors shall have the exclusive right and duty to acquire for the common areas of the Condominium.

(k) Any other materials, supplies, furniture, labor, services, maintenance, repairs, structural alterations or assessments which the Board of Directors is required to secure or pay for, pursuant to the terms of the Declaration or these Bylaws or which in its opinion shall be necessary or proper for the maintenance and operation of the Condominium as a first-class Condominium or for the enforcement of these restrictions, and which the Board of Directors determines should be assessed to the Owners under Section 5.4.

(l) The discharge of any mechanic's lien or other encumbrance levied against the entire Condominium or against the common areas of the Condominium, rather than merely against the interests therein of particular Owners. Where one or more Owners are responsible for the existence of such lien, they shall be jointly and severally liable for the cost of discharging it

and any costs incurred by the Board of Directors be reason of such lien or liens shall be specifically assessed to the responsible Owners.

(m) Maintenance and repair of any Unit if the Board of Directors determines that such maintenance or repair is necessary to protect the common areas of the Condominium, or any other portion of the Condominium, and the Owner of such Unit has failed or refused to perform such maintenance or repair within a reasonable time after written notice of the necessity of such maintenance or repair delivered by the Board of Directors to such Owner, provided that the Board of Directors shall levy a special assessment against such Owner for the cost of such maintenance or repair.

(n) Any other items properly chargeable as an expense of the Association.

5.3 Assessment of Common Expenses.

(a) **Obligation to pay.** All unit owners shall be obligated to pay common expenses assessed to them by the board of directors on behalf of the Association pursuant to these Bylaws and the Declaration. No unit owner by the owner's own action may claim exemption from liability for contribution towards common expenses by waiver by the owner of use or enjoyment of any of the common elements or by abandonment by the owner of the owner's unit. A unit owner may not claim an offset against an assessment for failure of the Association to perform its obligations and no unit owner may offset amounts owing or claimed to be owing by the Association or Declarant to the unit owner. Declarant shall be assessed as the unit owner of any unsold unit, but such assessments shall be prorated to the date of sale of the unit. The board of directors, on behalf of the Association shall assess the common expenses against the unit owners from time to time, and at least annually, and shall take prompt action to collect from a unit owner any common expense due that remains unpaid for more than thirty (30) days from the due date for its payment. The board may elect to round assessments to the nearest dollar.

(b) **Working capital fund.** At the time of closing of the initial sale of each unit to a person other than a successor declarant and thereafter on any subsequent sale of a unit, the purchaser shall make a contribution to the working capital of the Association equal to two (2) months' regular association assessments for the unit, which sums shall be held in a segregated working capital fund established in the name of the Association. At the time of the organizational and turnover meeting, the Declarant shall pay such contribution for all unsold units, but may obtain reimbursement for such sums from the purchaser upon the sale of each such unit. Such contribution shall be in addition to the regular monthly common expense assessment and shall not be considered as an advance payment of regular assessments. The working capital fund shall be held by the Association for deposit to a segregated fund at the time of the organizational and turnover meeting. Declarant may not use the working capital fund to defray any of Declarant's expenses, reserve contributions, or construction costs or to make up any budget deficits while Declarant is in control of the Association. After the organizational and turnover meeting, the board of directors, at its discretion, may use working capital funds for regular operating expenses, extraordinary items of maintenance, repair or replacement or capital additions, or may deposit all or a portion of such funds into the reserve account.

(c) **Commencement of regular operating expense assessments.** Regular monthly assessments for common operating expenses shall commence upon closing of the first sale of a unit in the Condominium. Declarant may elect to defer commencement of common operating expense assessments as to all units until the earlier of (i) the sale of 75 percent of the units in the Condominium have closed, or (ii) the turnover meeting described in Section 2.2 above. If Declarant so elects to defer commencement of assessments for operating expenses, Declarant shall pay and be responsible for all common operating expenses as they accrue, without cost or operating expense assessment to the other unit owners, until regular operating expense assessments commence. Declarant shall give 10 days' written notice to individual unit owners prior to the commencement of regular operating expense assessments.

(d) **Commencement of assessment for replacement reserves.** Regular monthly assessments for replacement reserves as described in Section 5.5 for all units in the Condominium shall commence upon the closing of the sale of the first unit in the Condominium. Declarant may elect to defer payment of such reserve assessments to the Association for each unit owned by Declarant until the closing of the sale of such unit, but not beyond the date of the turnover meeting referred to in Section 2.2 above, or if no turnover meeting is held, the date the owners assume administrative control of the Association. The books and records of the Association shall reflect the amount owing from Declarant for all reserve assessments.

5.4 **Special or Extraordinary Assessments.**

(a) **Special Assessments for Capital Improvements.** In the case of any duly authorized capital improvement to the common elements, the board of directors may by resolution establish separate assessments for the same, which may be treated as capital contributions by the unit owners, and the proceeds of which shall be used only for the specific capital improvements described in the resolution. The Association shall not assess units owned by the Declarant for additional capital improvements to the Condominium without the written consent of Declarant as long as Declarant owns more than five percent (5%) of the total units.

(b) **Other Special or Extraordinary Assessments.** In the event the board of directors determines that the assessments established upon adoption of the budget as provided in Section 5.1 above will be insufficient to pay the common expenses, or the board of directors determines that additional funds will be needed to meet unexpected or unbudgeted common expenses, the board may levy an additional special or extraordinary assessment. Such assessment shall be allocated to each unit in the same proportion set forth in the Declaration, and may be payable in installments over a specified period, in a lump sum, or in a lump sum with option to pay in installments with interest, as determined by the board of directors.

5.5 **Replacement Reserves.**

(a) **Establishment of Account.** The Declarant shall conduct a reserve study as described in paragraph (c) of this Section and establish a reserve account for replacement of those common elements all or a part of which will normally require replacement in more than three (3) and less than thirty (30) years, for significant future maintenance items as required by the Maintenance Manual established pursuant to Section 3.7(q) and for exterior painting if the

common elements include exterior painted surfaces. The reserve account need not include those items that could reasonably be funded from operating assessments.

(b) **Funding of Account.** The reserve account shall be funded by assessments against the individual units for the purposes for which the reserve account is being established, which sums shall be included in the regular monthly assessment for the unit, except as otherwise provided in Section 5.3(b). The reserve account shall be established in the name of the Association.

(c) **Reserve Studies.** The board of directors annually shall conduct a reserve study or review and update an existing study to determine the reserve account requirements for the items described in paragraph (a) of this Section and may adjust the amount of payments in accordance with the study or review and may provide for other reserve items that the board of directors, in its discretion, may deem appropriate. The reserve account need not include items that could reasonably be funded from operating assessments. The reserve study shall include:

- (1) Identification of all items for which reserves are to be established;
- (2) The estimated remaining useful life of each item as of the date of the reserve study;
- (3) An estimated cost of maintenance, repair or replacement of each item at the end of its useful life;
- (4) An update of the Maintenance Manual based upon the advice of competent experts or consultants; and
- (5) A thirty (30) year plan for the maintenance, repair and replacement of common elements and Association property with regular and adequate contributions, adjusted by estimated inflation and interest earned on reserves, to meet the maintenance, repair and replacement schedule.

The board of directors shall, within 30 days after conducting the reserve study, provide to every unit owner a written summary of the reserve study and of any revisions to the 30-year plan adopted by the board of directors or the Declarant as a result of the reserve study.

(d) **Use of Reserve Funds.** The reserve account shall be used only for the purposes for which the reserves have been established and shall be kept separate from other funds. After the organizational and turnover meeting described in Section 2.2, however, the board of directors may borrow funds from the reserve account to meet high seasonal demands on the regular operating funds or to meet unexpected increases in expenses if the board of directors has adopted a resolution, which may be an annual continuing resolution, authorizing the borrowing of funds. Not later than the adoption of the budget for the following year, the board of directors shall adopt by resolution a written payment plan providing for repayment of the borrowed funds within a reasonable period. In addition to the authority of the board of directors under paragraph (c) of this Section, after the organizational and turnover meeting, the Association may, on an annual basis, elect not to fund the reserve account described in paragraph

(a) of this Section by unanimous vote of the owners or elect to reduce or increase future assessments for the reserve account by an affirmative vote of at least seventy-five percent (75%) of the voting rights.

(e) **Sale of Units.** Nothing in this Section shall prohibit prudent investment of the reserve account. Assessments paid into the reserve account are the property of the Association and are not refundable to sellers of units. Sellers of the units, however, may treat their outstanding share of the reserve account as a separate item in any sales agreement.

5.6 **Default in Payment of Assessments.** In the event of default by any unit owner in paying any assessments to the Association, including assessed common expenses and any other charge imposed or levied by the Association pursuant to the provisions of the Declaration, these Bylaws or the Oregon Condominium Act, such unit owner shall be obligated to pay interest at the rate of twelve percent (12%) per annum on such assessment from the due date thereof, or at such greater rate as may be established by the board of directors from time to time, not to exceed the maximum lawful rate, if any. In addition, the defaulting unit owner shall pay a late charge for any assessment not paid within ten (10) days of its due date in the amount of five percent (5%) of the delinquent payment, or such other reasonable late charge or administrative fee, or both, as may be established by the board of directors from time to time by resolution that is delivered to each unit, mailed to the mailing address of each unit or mailed to the mailing address designated by the unit owner in writing, together with all expenses incurred by the Association in collecting such unpaid assessments, including attorneys' fees (whether or not suit is instituted, and at trial or any appeal or petition for review therefrom). If the assessment is not paid within thirty (30) days of its due date, the board of directors may declare any remaining installments of assessments for the balance of the fiscal year immediately due and payable and may terminate the right to receive utility services paid for out of assessments or the right of access to and use of recreational and service facilities of the Condominium until assessments have been brought current. The board of directors shall have the right and duty to recover for the Association such assessments, together with such charges, interest and expense of the proceeding, including attorneys' fees, by an action brought against such unit owner or by foreclosure of the lien upon the unit granted by the Oregon Condominium Act. The board of directors shall notify the holder of any first Mortgage upon a unit of any default not cured within sixty (60) days of the date of default.

5.7 **Foreclosure of Liens for Unpaid Assessments.** In any suit brought by the Association to foreclose a lien on a unit because of unpaid assessments, the unit owner shall be required to pay a reasonable rental for the use of the unit during the pendency of the suit, and the plaintiff in such foreclosure suit shall be entitled to the appointment of a receiver to collect such rental. The board of directors, acting on behalf of the Association, shall have the power to purchase such unit at the foreclosure sale and to acquire, hold, lease, Mortgage, vote the votes appurtenant to, convey, or otherwise deal with the unit. A suit or action to recover a money judgment for unpaid assessments shall be maintainable without foreclosing the liens securing the same.

5.8 **Statement of Assessments.** The board of directors shall advise each unit owner in writing of the amount of assessments payable by such owner, and furnish copies of each

budget on which such assessments are based to all unit owners and, if requested, to their Mortgagees. The board of directors shall promptly provide any unit owner who makes a request in writing with a written statement of the owner's unpaid assessments.

5.9 **Priority of Lien; First Mortgages.** To the extent provided by the Oregon Condominium Act, any lien of the Association against a unit for assessments shall be subordinate to tax and assessment liens and any first Mortgage of record. Unless otherwise provided in the Oregon Condominium Act, where the purchaser or Mortgagee of a unit obtains title to the unit as a result of foreclosure of a first Mortgage, such purchaser or Mortgagee, its successors and assigns, shall only be liable for a maximum of six (6) months of the assessments chargeable to such unit that became due prior to the acquisition of title to such unit by such purchaser or Mortgagee. Any additional unpaid share of assessments shall be a common expense and reallocated on a pro rata basis for all units, including the Mortgaged unit. The purchaser or Mortgagee shall not be relieved of the obligation to pay further assessments. A deed in lieu of foreclosure accepted by the holder of a first Mortgage shall extinguish a lien filed by the Association to secure unpaid assessments under the circumstances described in ORS 100.465.

5.10 **Voluntary Conveyance.** In a voluntary conveyance of a unit, the grantee shall be jointly and severally liable with the grantor for all unpaid assessments against the grantor of the unit up to the time of the grant or conveyance, without prejudice to the grantee's right to recover from the grantor the amounts paid by the grantee therefor. However, upon request of an owner or an owner's agent, for the benefit of a prospective purchaser, the board of directors shall make and deliver a statement of the unpaid assessments against the prospective grantor or the unit effective through a date specified in the statement, and the grantee in that case shall not be liable for any unpaid assessments against the grantor not included in the written statement.

Article 6

RECORDS AND AUDITS

6.1 **General Records.** The board of directors and the manager, if any, shall keep detailed records of the actions of the board of directors and the manager, minutes of the meetings of the board of directors and minutes of the meetings of the Association. The board of directors shall maintain a Book of Resolutions containing the rules, regulations and policies adopted by the Association, board of directors and the manager. The board of directors shall maintain a list of owners entitled to vote at meetings of the Association and a list of all Mortgagees of units. All documents, information and records delivered to the Association by the Declarant pursuant to ORS 100.210 and other records of the Association shall be kept within the State of Oregon for the time periods specified in ORS 100.480.

6.2 **Financial Records and Accounts.** The board of directors or its designee shall keep within the State of Oregon financial records sufficient for proper accounting purposes and as required by the Oregon Condominium Act. All assessments shall be deposited in a separate bank account, located in the State of Oregon, in the name of the Association. All expenses of the Association shall be paid from the Association's bank account.

6.3 **Assessment Roll.** The assessment roll shall be maintained in a set of accounting books in which there shall be an account for each unit. Such account shall designate the name and address of the owner or owners, the amount of each assessment against the owners, the dates and amounts in which the assessment comes due, the amounts paid upon the account and the balance due on the assessments.

6.4 **Payment of Vouchers.** The treasurer or manager shall pay all vouchers for all budgeted items and for any nonbudgeted items up to \$1,000 signed by the chairperson, managing agent, manager or other person authorized by the board of directors. Any voucher for nonbudgeted items in excess of \$1,000 shall require the authorization of the chairperson. Any checks written on reserve accounts must be signed by a member of the board of directors.

6.5 **Reports and Audits.** An annual financial statement consisting of a balance sheet and income and expense statement for the preceding fiscal year shall be rendered by the board of directors to all unit owners and to all Mortgagees of units who have requested the same within ninety (90) days after the end of each fiscal year. Commencing with the fiscal year following the Turnover Meeting, if the annual assessments exceed \$75,000 for the year, then the Board of Directors shall cause such financial statements to be reviewed within one hundred eighty (180) days after the end of the fiscal year by an independent certified public accountant licensed in Oregon in accordance with the Statements on Standards for Accounting and Review Services issued by the American Institute of Certified Public Accountants, or if the annual assessments are \$75,000 or less, shall cause such review within 180 days after receipt of a petition requesting such review signed by owners holding at least a majority of the voting rights. The board of directors need not cause such a review to be performed if so directed by an affirmative vote of unit owners holding at least sixty percent (60%) of the voting rights, not including votes of Declarant with respect to units owned by Declarant. Upon written request, any holder, insurer or guarantor of a first Mortgage shall be entitled to an audited financial statement for the immediately preceding fiscal year at the expense of the requesting party, if one is not otherwise available.

6.6 **Notice of Sale, Mortgage, Rental or Lease.** Upon the sale, mortgage, rental or lease of any unit, such unit owner shall promptly inform the secretary or manager of the name and address of the vendee, Mortgagee, lessee, or tenant.

6.7 **Availability of Records.** Except as otherwise provided in ORS 100.480(5)(b), during normal business hours or under other reasonable circumstances, the Association shall make reasonably available for examination and, upon written request, available for duplication, by unit owners, lenders and holders, insurers, or guarantors of any first Mortgage that make the request in good faith for a proper purpose, current copies of the Declaration, bylaws, other rules concerning the Condominium, amendments or supplements to such documents, and the books, records, financial statements and current operating budget of the Association. The Association, within ten (10) business days after receipt of a written request by a unit owner, shall furnish copies of such documents to the requesting unit owner. Upon written request, the Association shall make such documents, information and records available to such persons for duplication during reasonable hours. The board of directors, by resolution, may adopt reasonable rules governing the frequency, time, location, notice and manner of examination and duplication of

Association records and the imposition of a reasonable fee for furnishing copies of such documents, information or records. The fee may include reasonable personnel costs incurred to furnish the information.

6.8 **Statement of Assessments Due.** The Association shall provide, within ten (10) business days of receipt of a written request from an owner, a written statement that provides: (a) the amount of assessments due from the owner and unpaid at the time the request was received, including regular and special assessments, fines and other charges, accrued interest, and late payment charges; (b) the percentage rate at which interest accrues on assessments that are not paid when due; and (c) the percentage rate used to calculate the charges for late payment or the amount of a fixed rate charge for late payment. The Association is not required to comply with this Section if the Association has commenced litigation by filing a complaint against the owner and the litigation is pending when the statement would otherwise be due.

Article 7

MAINTENANCE AND USE OF CONDOMINIUM PROPERTY

7.1 **Maintenance and Repair.** Except as otherwise provided in Section 7.3 for damage or destruction caused by casualty:

(a) **Units.** All maintenance of and repairs to any unit shall be made by the owner of such unit, who shall keep the same in good order, condition and repair and shall do all redecorating, painting and staining that at any time may be necessary to maintain the good appearance and condition of the unit. In addition, each unit owner shall be responsible for the maintenance, repair, or replacement of interior doors, any plumbing, heating or air conditioning fixtures, telephones, water heaters, automatic garage door openers, fans, vents, lighting fixtures and lamps, electrical outlets, blinds, garbage disposals, fireplaces, refrigerators, dishwashers, ranges, or other appliances and accessories that may be in or connected with such owner's unit. The Association, however, may repair or replace, at the Association's expense, portions of units to the extent reasonably necessary for the preservation of the common elements in good condition and working order.

(b) **Common elements.** All maintenance, repairs and replacements to the general and limited common elements and to Association property shall be made by the Association and shall be charged to all the unit owners as a common expense. Each unit owner, however, shall keep the limited common elements that pertain to such owner's unit in a safe, neat, clean and sanitary condition.

(c) **Repairs.** For a period of ten (10) years following recording of the Declaration, any repairs to the Condominium shall be performed by the contractor or subcontractor who originally performed the work, or by such other licensed contractor as may have been approved in writing by Declarant. Failure to use such a contractor shall release Declarant and the original contractor or subcontractor from any past or future liability relating to the item so repaired.

7.2 Additions, Alterations or Improvements.

(a) A unit owner may not make any improvements or alterations to such owner's unit without first notifying the Association and obtaining approval by the board of directors of the proposed alteration. The owner shall have the burden of establishing, to the reasonable satisfaction of the board of directors, that the proposed improvements or alterations will not impair the structural integrity or mechanical systems of the Condominium, lessen the support of any portion of the Condominium, jeopardize the soundness or safety of the Condominium, reduce its value, impair any easement or hereditament, increase the common expenses or increase sound transmissions to other units. The board of directors may elect to require contractors to coordinate their access and working hours so as to minimize disruption to the Condominium. A unit owner shall reimburse the Association for any actual costs incurred by the Association in reviewing and monitoring such alterations.

(b) After acquiring an adjoining unit or an adjoining part of an adjoining unit, a unit owner may submit a written request to the board of directors for permission to remove or alter any intervening partition or to create apertures therein, even if the partition in whole or in part is a common element. The board of directors shall approve the change unless it determines within forty-five (45) days that the proposed change will impair the structural integrity or mechanical systems of the Condominium or lessen the support of any portion of the Condominium. The board of directors may require the unit owner, at such owner's own expense, to submit an opinion of a registered architect or registered professional engineer that the proposed change will not impair the structural integrity or mechanical systems of the Condominium or lessen the support of any portion of the Condominium. Removal of partitions or creation of apertures under this paragraph is not an alteration of boundaries.

(c) A unit owner may not change the appearance of the common elements or the exterior appearance of a unit without the prior written permission of the board of directors. No person shall install wiring for electrical or telephone installation, television antennas or satellite dishes, machines or air conditioning units, or similar devices on the exterior of the Condominium or cause them to protrude through the walls or the roof of the Condominium except as authorized by the board of directors. No exterior window guards, awnings, or shades shall be installed without prior consent of the board of directors.

7.3 Damage or Destruction by Casualty of Condominium Property. In the case of damage or destruction that affects a material portion of the Condominium, timely written notice shall be given to the unit owners and their Mortgagees and the following provisions shall apply:

(a) In the event of damage or destruction by casualty of Condominium property, the damage or destruction shall be repaired, reconstructed or rebuilt unless, within fourteen (14) days of such damage or destruction, the board of directors or unit owners holding more than ten percent (10%) of the voting rights shall have requested a special meeting of the Association. Such special meeting must be held within sixty (60) days of the date of damage or destruction. At the time of such meeting, unless unit owners holding ninety percent (90%) of the voting rights, whether in person, by writing or by proxy, with the approval of Mortgagees as required by the Declaration, vote not to repair, reconstruct or rebuild the damaged property, the

damage or destruction shall be repaired, reconstructed or rebuilt. If the damage or destruction is not repaired, reconstructed or rebuilt, then the property shall be removed from condominium ownership in the manner provided in the Oregon Condominium Act.

(b) The Association shall be responsible for repairing, reconstructing or rebuilding all such damage or destruction to the common elements and, to the extent of the Association's insurance coverage, all such damage or destruction to the units. Each unit owner shall be responsible for the cost of such repairing, reconstructing or rebuilding of his or her unit as is not so covered by the Association's insurance and to the extent of any deductible under the Association's insurance.

(c) If, due to the act or neglect of a unit owner, or of a member of such owner's family or household pet or of a guest or other occupant or visitor of such unit owner, damage shall be caused to the common elements or to a unit owned by others, or maintenance, repairs or replacements shall be required that would otherwise be a common expense, then such unit owner shall pay for such damage and such maintenance, repairs and replacements as may be determined by the Association, to the extent not fully covered by the Association's insurance.

(d) In the event any portion of the insurance proceeds paid to the Association is not used to repair, reconstruct or rebuild the damaged or destroyed property, the Association shall distribute the proceeds among the unit owners and their Mortgagees (as their interests may appear) in the same proportion as common expenses are shared, unless the property is removed from unit ownership. If the property is removed from unit ownership, the insurance proceeds, together with the proceeds from the sale of the property, shall be distributed to the unit owners and their Mortgagees (as their interests may appear) in the manner described in the Oregon Condominium Act.

7.4 **Condemnation.** If any portion of the Condominium is made the subject matter of any condemnation or eminent domain proceeding or is otherwise sought to be acquired by a condemning authority, notice of the proceeding or proposed acquisition shall promptly be given to each unit owner and to each Mortgagee. The Association shall represent the unit owners in any condemnation proceedings or in negotiations, settlements and agreements with the condemning authority for acquisition of any portion of the common elements, and each unit owner appoints the Association to act as his attorney-in-fact for such purposes. All compensation, damages or other proceeds of the taking, other than any award for moving expenses of specific unit owners, shall be payable to the Association and allocated and distributed as provided in this Section 7.4.

(a) **Complete Taking.** If the entire Condominium property is taken, or if unit owners holding ninety percent (90%) of the voting rights agree that such substantial portion of the Condominium has been taken as to make the project obsolete, then the property shall be deemed removed from unit ownership. In such event, any proceeds of the condemnation paid to the Association, together with any other proceeds upon sale of the remaining Condominium property, shall be distributed among the unit owners and their Mortgagees, as their interests may appear, in accordance with the provisions of the Oregon Condominium Act.

(b) **Partial Taking.** If less than the entire Condominium property is taken and the property is not determined to be obsolete as provided in paragraph (a) above, then as soon as practicable the board of directors shall, reasonably and in good faith, allocate the award among the units in accordance with the reduction in the value of each unit and its interest in the common elements, compared to the total reduction in value of all units and their interest in the common elements. In the event any unit owner or Mortgagee objects to the allocation determined by the board of directors, the matter shall be submitted to arbitration in accordance with Article 10 below. The cost of such determination shall be paid out of the proceeds of the condemnation. Any portion of the award allocated to a unit owner under this paragraph shall be paid first to all Mortgagees and holders of liens on the unit owner's interest in accordance with the existing priorities, and the balance to the unit owner. If any reconstruction or repair is undertaken as a result of the condemnation, the board of directors may retain and apply such portion of each unit owner's share of the award as is necessary to discharge the owner's liability for any special assessment arising from such reconstruction or repair.

7.5 **Restrictions and Requirements Respecting Use of Condominium Property.** The following restrictions and requirements are in addition to all other restrictions and requirements contained in the Declaration and these Bylaws:

(a) **Residential use.** No commercial activities of any kind shall be carried on in any Living Unit or in any other portion of the Condominium without the consent of the board of directors of the Association, except activities relating to the rental or sale of units. This provision, however, shall not be construed so as to prevent or prohibit a unit owner from maintaining his or her professional personal library, keeping his or her personal business or professional records or accounts, handling his or her personal business or professional telephone calls, or conferring with business or professional associates, clients or customers, in such owner's unit.

(b) **Use of common elements.** The common elements shall be used for the furnishing of services and facilities for which the same are reasonably intended, for the enjoyment of the units. The use, operation and maintenance of the common elements shall not be obstructed, damaged or unreasonably interfered with by any unit owner.

(c) **Offensive or unlawful activities.** No noxious or offensive activities shall be carried on in any unit nor shall anything be done in or placed upon any unit or common element that interferes with or jeopardizes the enjoyment of other units or the common elements or which is a source of annoyance to residents. Unit occupants shall exercise extreme care not to make noises that may disturb other unit occupants, including the use of musical instruments, radios, televisions and amplifiers. Speakers for audio equipment may not be mounted on or against walls or floors without an adequate sound barrier to prevent vibration and transmission of bass sounds outside of the unit. Occupants may not discard or throw items out of windows or from decks, including, without limitation cigarettes or ashes. No unlawful use shall be made of the Condominium nor any part thereof, and all valid laws, zoning ordinances, and regulations of all governmental bodies having jurisdiction thereof shall be observed. Owners and other occupants shall not engage in any abusive or harassing behavior, either verbal or physical, or any

form of intimidation or aggression directed at other owners, occupants, guests, or invitees, or directed at the manager, its agents or employees, or vendors.

(d) **Animals.** No animals or fowls shall be raised, kept or permitted within the Condominium or any part thereof, except not more than two dogs or two cats or one dog and one cat, and a reasonable number of other ordinary household pets kept within a unit. No such dogs shall be permitted to run at large, nor shall any dogs, cats or pets be kept, bred or raised for commercial purposes. Any inconvenience, damage or unpleasantness caused by such pets shall be the responsibility of the respective owners thereof, and owners shall be responsible for clean up and removal of wastes of their animals. No Rotweillers, Pit Bulls or Canary Island dogs are permitted within the Condominium. All pets shall be kept under reasonable control at all times and shall be carried or kept on a leash while outside a unit. Each Owner and occupant shall be responsible for seeing that his or her pets do not endanger health, make objectionable noise, or constitute a nuisance or inconvenience to the Owners and occupants of other units. The board of directors, after notice and a hearing, may require the permanent removal of any animal that the board determines to be a danger to the health and safety of any occupant in the Condominium, or otherwise to be a nuisance within the Condominium. The board may find that an animal is a nuisance if the animal or its owner continue to violate these Bylaws or the rules regulating pets after receipt by the Owner of a written demand from the board to comply with these Bylaws or the rules.

(e) **Exterior lighting or noisemaking devices and antennas.** Except with the consent of the board of directors of the Association, no exterior lighting or noisemaking devices shall be installed or maintained on any unit. Seasonal holiday lighting and decorations are permissible if consistent with any applicable rules and regulations and if removed within thirty (30) days after the celebrated holiday. Exterior antennas, satellite receiver and transmission dishes and other communication devices shall not be permitted to be placed upon the general common elements, and may not be placed on any unit or limited common element except in accordance with rules established by the board of directors.

(f) **Windows, decks, and outside walls.** In order to preserve the attractive appearance of the Condominium the board of directors of the Association may adopt rules regulating the nature of items that may be placed in or on windows, decks, and the outside walls so as to be visible from other units, the common elements, or outside the Condominium. Garments, rugs, laundry, sheets, reflective surfaces and other similar items may not be hung from windows, facades, patios or decks.

(g) **Signs.** Unless written approval is first obtained from the board of directors, no sign of any kind shall be displayed to the public view on or from any unit or the common elements except signs used by the Declarant to advertise units for sale or lease.

(h) **Trash.** No part of any unit or any part of the common elements shall be used or maintained as a dumping ground for rubbish, trash, garbage, recycling materials or other waste. No garbage, trash, recycling materials or other waste shall be kept or maintained on any part of the property, except in sanitary containers in the designated areas.

(i) **Insurance.** Nothing shall be done or kept in any unit or in the common elements that will increase the cost of insurance on the common elements. No owner shall permit anything to be done or kept in his or her unit or in the common elements that will result in cancellation of insurance on any unit or any part of the common elements.

(j) **Water beds.** Water beds may not be placed in any unit, except with the prior consent of the board of directors. If such consent is given, the unit owner shall carry insurance covering damage caused by the water bed and shall be responsible for all damages to any unit or the common elements that might be caused by the water bed.

(k) **Washing Machines.** Each unit contains a washing machine hookup. The unit owner shall be responsible for all damages to any unit or the common elements that might be caused by the washing machine or leakage from the washing machine.

(l) **Association rules and regulations.** In addition, the board of directors from time to time may adopt, modify, or revoke such rules and regulations governing the conduct of persons and the operation and use of the units and common elements as it may deem necessary or appropriate in order to assure the peaceful and orderly use and enjoyment of the Condominium property, including, without limitation, establishment of reasonable administrative fees, such as fees for new owner set-up and owner's packet, move-in and move-out fees, etc. Any action by the board of directors adopting, modifying or revoking any rule or regulation may be overruled by a vote of not less than seventy-five percent (75%) of the voting rights present, in person or by proxy, at any meeting, the notice of which shall have stated that such adoption, modification or revocation of rules and regulations will be under consideration. A copy of the rules and regulations, upon adoption, and a copy of each amendment, modification or revocation thereof, shall be delivered by the secretary promptly to each unit owner and shall be binding upon all unit owners and occupants of all units from the date of delivery.

7.6 **Leasing and Rental of Units.**

(a) Any owner who wishes to lease or rent his or her unit must meet each of the following requirements, and the lease or rental agreement will be subject to these requirements whether or not they are included within the lease or rental agreement:

- (1) all leases and rentals must be in writing;
- (2) the unit may not be rented for transient or hotel purposes, and all leases and rentals shall be for a term of not less than thirty (30) days;
- (3) the lease or rental must be for the entire unit and not merely parts of the unit, unless the owner remains in occupancy;
- (4) all such leases and rentals shall be subject in all respects to provisions of the Declaration, these Bylaws, and all rules and regulations adopted by the Board;
- (5) all owners who lease or rent their units shall promptly notify the Association in writing of the names of all tenants and members of tenants' family occupying such

units and shall provide the Association with a complete copy of the lease or rental agreement. All owners leasing their unit shall promptly notify the Association of the address and telephone number where such owner can be reached.

(b) Any failure of a tenant to comply with the Declaration, Bylaws, and Association rules and regulations, shall be a default under the lease or rental agreement, regardless of whether the lease or rental agreement so provides. In the event of any such default, the owner immediately shall take all actions to cure the default including, if necessary, eviction of the tenant;

(c) If any tenant is in violation of the provisions of the Declaration, Bylaws, or rules and regulations of the Association, the Association may bring an action in its own name and/or in the name of the owner to have the tenant evicted and/or to recover damages. If the court finds that the tenant is violating, or has violated any of the provisions of the Declaration, these Bylaws, or the rules and regulations of the Association, the court may find the tenant guilty of unlawful detainer notwithstanding the fact that the owner is not the plaintiff in the action and/or the tenant is not otherwise in violation of tenant's lease. The remedy provided by this subsection is not exclusive and is in addition to any other remedy or remedies which the Association may have. If permitted by present or future law, the Association may recover all its costs, including court costs and reasonable attorneys' fees incurred in prosecuting the unlawful detainer action.

(d) The Association shall give the tenant and the owner notice in writing of the nature of the violation, and twenty (20) days from the mailing of the notice in which to cure the violation before the Association may file for eviction.

(e) Each owner shall provide a copy of the Declaration, these Bylaws and all rules and regulations of the Association to each tenant of his or her unit. By becoming a tenant, each tenant agrees to be bound by the Declaration, these Bylaws and the rules and regulations of the Association, and recognizes and accepts the right and power of the Association to evict a tenant for any violation by the tenant of the Declaration, these Bylaws, and rules and regulations of the Association.

7.7 Failure to Follow Maintenance Manual.

(a) **Association.** The Association shall perform all inspections and maintenance as recommended by the Maintenance Manual described in Section 3.7(q) above and make such repairs and maintenance as may be necessary to reasonably address the results of the inspections. If the Association fails to follow such maintenance and inspection requirements, then neither the Association nor any unit owner shall have any claim against Declarant or its design professionals, contractors and subcontractors and their consultants, including without limitation, all of their officers, members, directors, employees, agents, brokers and affiliates, for loss or damage to the extent the same results from such failure to follow the Maintenance Manual, and shall indemnify such persons and entities from and against claims by unit owners or other persons or entities for loss or damage resulting from such failure.

(b) **Unit Owners.** Each unit owner shall perform such inspections of and maintenance to the owner's unit as may be recommended by the Owner's Maintenance Manual prepared by Declarant. If the unit owner fails to follow such inspections and maintenance recommendations, neither the unit owner nor the Association shall have any claim against Declarant or its design professionals, contractors and subcontractors and their consultants, including without limitation, all of their officers, members, directors, employees, agents, brokers and affiliates, for loss or damage to the extent the same results from such failure to follow the Owner's Maintenance Manual, and shall indemnify such persons and entities from and against claims by the Association, unit owners or other persons or entities for loss or damage resulting from such failure.

7.8 **Abatement and Enjoining of Violations.** The violation of any provision of the Declaration or these Bylaws, of any rule or regulation adopted pursuant to these Bylaws, or of any decision of the Association made pursuant to such documents, shall give the board of directors, acting on behalf of the Association, the right, in addition to any other rights set forth in these Bylaws, to do any or all of the following after giving written notice and an opportunity to be heard:

(a) to summarily abate and remove, at the expense of the defaulting unit owner, any structure, thing, or condition that may exist contrary to the intent and meaning of such provisions, and the board of directors shall not thereby be deemed guilty of any manner of trespass, provided, however, that judicial proceedings shall be instituted before any items of construction may be altered or demolished; or

(b) to enjoin, abate, or remedy such thing or condition by appropriate legal proceedings; or

(c) to levy reasonable fines based upon a resolution adopted by the board of directors that is delivered to each unit, mailed to the mailing address of each unit or mailed to the mailing address designated by the owner of each unit in writing; or

(d) to terminate the right to receive utility services paid for out of assessments or the right of access to and use of recreational and service facilities of the Condominium until the correction of the violation has occurred.

The offending unit owner shall be liable to the Association for a reasonable administrative fee as established by the board of directors and all costs and attorneys' fees incurred by the Association, whether or not legal proceedings are instituted and including attorneys' fees at trial, in arbitration or on appeal or petition for review, together with any expense incurred by the Association in remedying the default, damage incurred by the Association or unit owners, or fines so levied. Such sums shall be assessed against the offending unit as an assessment and enforced as provided in Article 5. In addition, any aggrieved unit owner may bring an action against such other unit owner or the Association to recover damages or to enjoin, abate, or remedy such thing or condition by appropriate legal proceedings.

Article 8

INSURANCE

8.1 **Types of Insurance.** For the benefit of the Association and the unit owners, the board of directors shall obtain and maintain at all times, and shall pay for out of the common expense funds, the following insurance:

(a) **Property Damage Insurance.**

(1) The Association shall maintain a policy or policies of insurance covering loss or damage from fire, with standard extended coverage and “all risk” endorsements, and such other coverages as the Association may deem desirable.

(2) The amount of the coverage shall be for not less than one hundred percent (100%) of the current replacement cost of the units and common elements (exclusive of land, foundation, excavation and other items normally excluded from coverage), subject to a maximum deductible of the lesser of \$10,000 or one percent (1%) of the policy amount.

(3) The policy or policies shall include all fixtures and building service equipment to the extent that they are part of the common elements and all personal property and supplies belonging to the Association, together with all fixtures, improvements and alterations comprising a part of each unit.

(4) Such policy or policies shall name the Association as insured, and shall provide for loss payable in favor of the Association, as a trustee for each unit owner and each such unit owner's Mortgagee, as their interests may appear. The policies shall contain the standard mortgage clause, or equivalent endorsement (without contribution) that is commonly accepted by institutional mortgage investors in Oregon.

(b) **Liability Insurance.**

(1) The Association shall maintain comprehensive general liability insurance coverage insuring the Declarant, the Association, the board of directors, the unit owners and the manager, against liability to the public or to the owners of units and of common elements, and their invitees or tenants, incident to the operation, maintenance, ownership or use of the property, including legal liability arising out of lawsuits related to employment contracts of the Association. There may be excluded from such policy or policies coverage of a unit owner (other than as a member of the Association or board of directors) for liability arising out of acts or omission of such unit owner and liability incident to the ownership and/or use of the part of the property as to which such unit owner has the exclusive use or occupancy.

(2) Limits of liability under such insurance shall not be less than One Million Dollars (\$1,000,000) on a combined single limit basis.

(3) Such policy or policies shall be issued on a comprehensive liability basis and shall provide a cross liability endorsement wherein the rights of named insured under

the policy or policies shall not be prejudiced as respects his, her or their action against another named insured.

(c) **Workers' Compensation Insurance.** The Association shall maintain workers' compensation insurance to the extent necessary to comply with any applicable laws.

(d) **Fidelity Insurance.**

(1) The Association shall maintain fidelity insurance for all officers, directors, trustees and employees of the Association and all other persons handling or responsible for funds of or administered by the Association. In the event the Association has retained a manager, such manager shall maintain fidelity insurance for its officers, employees and agents handling or responsible for funds of, or administered on behalf of, the Association. The cost of such insurance shall be at the expense of the Association.

(2) The total amount of fidelity insurance coverage required shall be based upon the best business judgment of the board of directors. In no event, however, may the aggregate amount of such insurance be less than the sum equal to three months' aggregate assessments on all units plus reserve funds.

(3) Such fidelity insurance shall name the Association as obligee and shall contain waivers by the issuers of the insurance of all defenses based upon the exclusion of persons serving without compensation from the definition of "employees" or similar terms or expressions. The insurance shall provide that it may not be canceled or substantially modified (including cancellation for nonpayment of premium) without at least ten (10) days' prior written notice to the Association and each servicer on behalf of the Federal National Mortgage Association ("FannieMae").

(e) **Directors' and Officers' Liability Insurance.** The Association shall maintain a policy of directors' and officers' liability insurance with coverage in the amount of not less than One Million Dollars (\$1,000,000), subject to a reasonable deductible.

(f) **Insurance by Unit Owners.** The Association has no responsibility to procure or assist in procuring property loss insurance for any owner or tenant for (i) damage to a unit or limited common elements not covered by the Association's policy (because of the deductible amount or because the claim for loss or damage is one not covered by fire and property loss insurance policies required by these Bylaws or held by the Association); or (ii) for any damage or loss to the owner's or tenant's personal property. Owners must be responsible for purchasing insurance policies insuring their units and appurtenant limited common elements for the deductible amount under the Association's policies and for insuring their own personal property for any loss or damage. Proof of such insurance coverage must be provided to the Association by the unit owner. Tenants must be responsible for insuring their own personal property for any loss or damage. The Association shall notify all owners of the amount of the deductible under the Association policies. To the extent reasonably practicable, the Association shall give at least thirty (30) days' notice to the owners of any increase in the deductible proposed in renewal or replacement insurance policies. Owners and tenants of all units must

procure and maintain comprehensive liability policies having combined limits in amounts reasonably set by the board of directors no more often than every three years. Such insurance must provide coverage for, without limitation, the negligent acts of the owner and tenant and their guests or other occupants of the unit for damage to the general and limited common elements and other units and the personal property of others located therein.

8.2 **Other Insurance Requirements.** Insurance obtained by the Association shall be governed by the following requirements:

(a) All policies shall be written with the State of Oregon or a company licensed to do business in the State of Oregon acceptable to FannieMae which falls into a “B” or better general policyholder’s rating or a “6” or better financial performance index rating in Best’s Insurance Reports, an “A” or better general policyholder’s rating and a financial size category of “VIII” or better in Best’s Insurance Reports – International Edition, an “A” or better rating in Demotech’s Hazard Insurance Financial Stability Ratings, a “BBBq” qualified solvency ratio or a “BBB” or better claims—paying ability rating in Standard and Poor’s Insurer Solvency Review, or a “BBB” or better claims – paying ability in Standard and Poor’s International Confidential Rating Service.

(b) Notwithstanding the provisions of Section 8.1 above, there may be named as an insured, on behalf of the Association, the Association's authorized representative, including any trustee with whom the Association may enter into any Insurance Trust Agreement, or any successor to such trustee. Such insurance trustee shall have exclusive authority to negotiate losses under any property or liability insurance policy. Each unit owner appoints the Association, or any insurance trustee or substitute trustee designated by the Association, as attorney-in-fact for the purpose of purchasing and maintaining such insurance including: the collection and appropriate disposition of the proceeds thereof, the negotiation of losses and execution of releases of liability, the execution of all documents, and the performance of all other acts necessary to accomplish such purchase. The Association or insurance trustee shall receive, hold or otherwise properly dispose of any proceeds of insurance in trust for unit owners and their first Mortgage holders, as their interests may appear.

(c) All property insurance policies shall contain a “Special Condominium Endorsement” or its equivalent providing for the following: recognition of any Insurance Trust Agreement, a waiver of the right of subrogation against unit owners individually, that the insurance is not prejudiced by any act or neglect of individual unit owners that is not in the control of such owners collectively, and that the policy is primary in the event the unit owner has other insurance covering the same loss.

(d) For purposes of this article, insurance policies are unacceptable where (i) under the terms of the insurance carrier's charter, bylaws or policy, contributions or assessments may be made against FannieMae, the designee of FannieMae, or the Association or unit owners, or (ii) by the terms of the carrier's charter, bylaws or policy, loss payments are contingent upon action by the carrier's board of directors, policy holders or members, or (iii) policy includes any limiting clauses (other than insurance conditions) that could prevent FannieMae or the owners from collecting insurance proceeds.

(e) All policies required by this article shall provide that they may not be canceled or substantially modified without at least ten (10) days' prior written notice to the Association and to each holder of a first Mortgage which is listed as a scheduled holder of a first Mortgage in the insurance policy. Evidence of insurance shall be issued to each unit owner and Mortgagee upon request.

(f) Each unit owner shall be required to notify the board of directors of all improvements made by the owner to his or her unit, the value of which is in excess of Five Hundred Dollars (\$500). Nothing in this paragraph shall permit an owner to make improvements without first obtaining the approval of the board of directors pursuant to Section 7.2.

(g) Any unit owner who obtains individual insurance policies covering any portion of the property other than such owner's personal property and fixtures shall file a copy of such individual policy or policies with the Association within thirty (30) days after the purchase of such insurance.

8.3 **Optional Provisions.** The board of directors shall make every effort to secure insurance policies that will provide for the following:

(a) To the extent appropriate and available at reasonable cost, the Association shall maintain additional coverages against such other risks as are customarily covered with respect to projects similar in construction, location and use, including but not limited to, host liquor liability, contractual and all-written contract insurance, employer's liability insurance, comprehensive automobile liability insurance, and an endorsement patterned after "use and occupancy" insurance providing relief from monthly assessments while a unit is uninhabitable due to a covered loss.

(b) If reasonably available, the insurance policies shall include Inflation Guard Endorsement, and Construction Code Endorsements (such as a Demolition Cost Endorsement, a Contingent Liability from Operation of Building Laws Endorsement, and an Increased Cost of Construction Endorsement).

(c) A Steam Boiler and Machinery Coverage Endorsement if the Condominium has central heating or cooling, which coverage per accident shall at least equal the lesser of Two Million Dollars (\$2,000,000) or the insurable value of the building housing the boiler or machinery.

(d) Flood Insurance, if the Condominium is in a Special Flood Hazard Area.

(e) If reasonably available, waiver of subrogation by the insurer as to any claims against the board of directors, any unit owner or any guest of a unit owner.

8.4 **FannieMae and GNMA Requirements.** Notwithstanding any other provisions of this article, the Association shall continuously maintain in effect such casualty, flood and liability insurance and a fidelity bond meeting the insurance and fidelity requirements for condominium projects established by FannieMae, the Federal Home Loan Mortgage Corporation, and Government National Mortgage Association, so long as they are a Mortgagee

or owner of a unit within the Condominium, except to the extent such coverage is not available or has been waived in writing by FannieMae, the Federal Home Loan Mortgage Corporation, or Government National Mortgage Association. FannieMae, the Federal Home Loan Mortgage Corporation, or their servicers, their successors and assigns, shall be named as a Mortgagee in the Association's policies.

Article 9

AMENDMENTS TO BYLAWS

9.1 **How Proposed.** Amendments to the bylaws shall be proposed by either a majority of the board of directors or by unit owners holding thirty percent (30%) of the voting rights. The proposed amendment must be reduced to writing and shall be included in the notice of any meeting at which action is to be taken thereon or attached to any request for consent to the amendment.

9.2 **Adoption.** A resolution adopting a proposed amendment may be proposed by either the board of directors or by the unit owners and may be approved by the unit owners at a meeting called for this purpose or by ballot vote. Unit owners not present at the meeting considering such amendment may express their approval in writing or by proxy. Any resolution must be approved by unit owners holding a majority of the voting rights and by Mortgagees to the extent required by the Declaration, except that (a) any provision of these Bylaws that is also contained in the Declaration must be approved by the same voting requirement for amendment of such provision of the Declaration, and (b) any amendment relating to age restrictions, pet restrictions, limitations on the number of persons who may occupy units, or limitations on the rental or leasing of units must be approved by unit owners holding seventy-five percent (75%) of the voting rights. Declarant's consent shall also be required so long as Declarant owns twenty-five percent (25%) or more of the Living Units in the Condominium. Such consent shall not be required after ten (10) years from the date of conveyance of the first Living Unit to a person other than a successor declarant. Any amendment that would limit or diminish any special Declarant rights established in these Bylaws shall require the written consent of Declarant and any amendment to Sections 3.7, 3.16, 7.7, 9.2 and 10.3 of these Bylaws shall require the written consent of Declarant for a period of ten (10) years after the date of the Organizational and Turnover Meeting described in Section 2.2.

9.3 **Execution and Recording.** An amendment shall not be effective until certified by the chairperson and secretary of the Association as being adopted in accordance with these Bylaws and the provisions of the Oregon Condominium Act and recorded as required by law. Any amendment adopted within five (5) years after the recording of the initial bylaws shall be approved by the Oregon Real Estate Commissioner to the extent required by the Oregon Condominium Act.

Article 10

DISPUTE RESOLUTION

10.1 **Claims Other than for Defective or Negligent Construction.** The following provisions of this Section 10.1(a) shall apply to any claim, controversy or dispute by or among Declarant (including members, officers, directors, shareholders and affiliates of Declarant), the Association, the manager or one or more unit owners, or any of them, arising out of or related to the Declaration, these Bylaws or the Condominium, other than claims relating to defective or negligent construction as provided in Section 10.2 below:

(a) **Mediation.**

(1) Except as otherwise provided in this Section 10.1(a), before initiating litigation, arbitration or an administrative proceeding in which the Association and an owner have an adversarial relationship, the party that intends to initiate litigation, arbitration or an administrative proceeding shall offer to use any dispute resolution program available within Multnomah County, Oregon, that is in substantial compliance with the standards and guidelines adopted under ORS 36.175. The written offer must be hand delivered or mailed by certified mail, return receipt requested, to the address, contained in the records of the Association, for the other party.

(2) If the party receiving the offer does not accept the offer within 10 days after receipt by written notice hand delivered or mailed by certified mail, return receipt requested, to the address, contained in the records of the Association, for the other party, the initiating party may commence the litigation, arbitration or the administrative proceeding. The notice of acceptance of the offer to participate in the program must contain the name, address and telephone number of the body administering the dispute resolution program.

(3) If a qualified dispute resolution program exists within Multnomah County, Oregon, and an offer to use the program is not made as required under paragraph (1) of this Section 10.1(a), litigation, arbitration or an administrative proceeding may be stayed for thirty (30) days upon a motion of the noninitiating party. If the litigation, arbitration or administrative action is stayed under this paragraph, both parties shall participate in the dispute resolution process.

(4) Unless a stay has been granted under paragraph (3) of this Section 10.1(a), if the dispute resolution process is not completed within thirty (30) days after receipt of the initial offer, the initiating party may commence litigation, arbitration or an administrative proceeding without regard to whether the dispute resolution is completed.

(5) Once made, the decision of the court, arbitrator or administrative body arising from litigation, arbitration or an administrative proceeding may not be set aside on the grounds that an offer to use a dispute resolution program was not made.

(6) The requirements of this Section 10.1(a) do not apply to circumstances in which irreparable harm to a party will occur due to delay or to litigation,

arbitration or an administrative proceeding initiated to collect assessments, other than assessments attributable to fines.

(b) **Arbitration.** Any such claim, controversy or dispute shall be first subject to mediation as provided in Section 10.1(a) above or otherwise, and, if not timely settled by mediation, resolved by arbitration in accordance with this Section 10.3 below. The decision and award of the arbitrator shall be final, binding and nonappealable.

(c) **Excluded Matters.** Notwithstanding the foregoing, the following matters shall not be subject to mediation or arbitration under this Section 10.1 (but shall be subject to the applicable provisions of Section 10.1(d) below): (i) actions relating to the collection of fees, assessments, fines and other charges imposed or levied by the Association (other than disputes as to the validity or amount of such fees, assessments, fines or charges, which disputes shall be subject to mediation/arbitration as provided above), and (ii) actions to enforce any order, decision or award rendered by arbitration pursuant to Section 10.3. The filing of a lis pendens or the application to any court for the issuance of any provisional process or similar remedy described in the Oregon or Federal Rules of Civil Procedure shall not constitute a waiver of the right or duty to utilize the procedures specified in this Section 10.1.

(d) **Costs and Attorneys' Fees.** The fees of any mediator and the costs of mediation shall be divided and paid equally by the parties. Each party shall pay its own attorneys' fees and costs in connection with any mediation. The fees of any arbitrator and the costs of arbitration shall be paid by the nonprevailing party or parties; if none, such fees and costs shall be divided and paid equally by the parties. Except as otherwise provided in Section 10.2(e) below, should any suit, action or arbitration be commenced in connection with any dispute related to or arising out of the Declaration or these Bylaws, to obtain a judicial construction of any provision of the Declaration or these Bylaws, to rescind the Declaration or these Bylaws or to enforce or collect any judgment or decree of any court or any award obtained during arbitration, the prevailing party shall be entitled to recover its costs and disbursements, together with such investigation, expert witness and attorneys' fees incurred in connection with such dispute, as the court or arbitrator may adjudge reasonable, at trial, in the arbitration, upon any motion for reconsideration, upon petition for review, and on any appeal of such suit, action or arbitration proceeding. The determination of who is the prevailing party and the amount of reasonable attorneys' fees to be paid to the prevailing party shall be decided by the arbitrator (with respect to attorneys' fees incurred prior to and during the arbitration proceeding) and by the court or courts, including any appellate or review court, in which such matter is tried, heard or decided, including a court that hears a request to compel or enjoin arbitration or that hears exceptions made to an arbitration award submitted to it for confirmation as a judgment (with respect to attorneys' fees incurred in such proceedings).

10.2 **Claims for Negligent or Defective Construction.** The following alternative dispute resolution procedures shall apply to any claim by the Association or any unit owner against Declarant or any contractor, subcontractor, supplier, consultant or design professional of every tier performing any work or services in connection with the Condominium, and their agents, brokers, successors, employees, affiliates, representatives, officers, directors and members, and their insurers and re-insurers, related to the design or construction of the

Condominium, including, but not limited to, claims for defective or negligent construction or design.

(a) **Initial Dispute Resolution Procedures.** In the event of a claim for a construction defect governed by ORS 701.550 to 701.595, the parties shall first comply with the provisions contained therein. In the event the claim is not for a construction defect governed by such provisions, but relates to a claimed defect in the condition of the project, the parties shall follow the same procedures as set forth in such provisions, except that the notice of defect shall include a statement of the basis upon which the recipient is claimed to be liable for the defect. Compliance with the procedures contained in this Section 10.2(a) shall be a condition precedent to mediation, arbitration or litigation of any such Claims.

(b) **Mediation.** If the initial dispute resolution proceedings under Section 10.2(a) do not resolve the claims, the parties shall then engage in mediation to resolve the claims. The fees of any mediator and the costs of mediation shall be divided and paid equally by the parties. Each party shall pay its own attorneys' fees and costs in connection with any mediation. Completion of the mediation process under this section shall be a condition precedent to the filing of any arbitration or litigation proceedings or any claims relating to the matter with the Oregon Construction Contractors Board, and the Association and unit owners waive any right to file any such claims if the Association and unit owners have not fully complied with this Section 10.2(b). The mediation shall be conducted in accordance with the following procedures:

(1) Within sixty (60) days after completion of the proceedings under Section 10.2(a) and delivery of a demand for mediation by one of the parties to the other parties, the parties shall agree upon a neutral mediator. If the parties are unable to agree on a mediator within that period, upon application of any party, the Presiding Judge of the Circuit Court of Multnomah County, Oregon, shall designate the mediator.

(2) Within sixty (60) days after delivery of the demand for mediation, the parties shall exchange with each other all inspection and consultant's reports in their possession pertaining to the claims.

(3) The parties shall have ninety (90) days after exchanging reports in which to perform additional inspections. Any additional reports resulting from such inspections shall be furnished to the other parties prior to mediation.

(4) The mediation shall be conducted after completing parts (1) and (3) above, but within one hundred eighty (180) days following delivery of the demand for mediation. The mediator may elect to adjourn the mediation to additional sessions if the mediator determines that further sessions would be beneficial in resolving the disputes.

(5) Each party shall send to the mediation a representative with authority to settle the dispute and will attempt in good faith to resolve all disputes in the mediation.

(6) Any settlement agreed upon in mediation shall be documented and executed within 60 days following completion of the mediation.

(c) **Arbitration.** All claims that have not been resolved by mediation shall be resolved by arbitration in accordance with Section 10.3 below. The decision and award of the arbitrator shall be final, binding and nonappealable.

(d) **Third Parties.** Upon demand by any party, claims between or among the parties and third parties shall be submitted in a single, consolidated arbitration. Notwithstanding the provisions of Section 10.2(c) above, in the event any claim involves a claim by either party against a third party who is not required to and does not voluntarily agree to submit such claim to arbitration, then either party may elect to have the claim and the third party claim determined by a court of law in a consolidated proceeding, rather than by arbitration. In such case, the parties waive trial by jury and agree that the matter shall be determined by a judge sitting without a jury.

(e) **Attorney Fees.** In the event of any claim determined by arbitration or by a court of law under Sections 10.2(c) or 10.2(d) above, each party shall bear their own costs, including, without limitation, filing fees, attorney's fees, investigation expenses, consultant's fees and expert's fees. The other costs of arbitration and other court costs shall be divided and paid equally by the parties. To the extent permitted by law, statutory attorney's fees under the Unlawful Trade Practices Act or any other applicable statute are hereby waived.

(f) **Confidentiality.** The parties shall keep all discussions of disputes, settlements and arbitration awards and decisions confidential and shall not disclose any such information, whether directly or indirectly, to any third parties other than their attorneys and consultants, unless compelled to do so by an order of a court of competent jurisdiction. In the event of a breach of this confidentiality obligation, the other party shall be entitled to seek and obtain any and all equitable remedies, including injunctive relief and specific performance, and the breaching party waives any claim or defense that the other party has an adequate remedy at law for any such breach, and such party shall not be required to post any bond or other security in connection with any such equitable relief.

(g) **Time Periods within which Claims must be Asserted.**

(1) **Statutory Warranty Claims.** A written claim reasonably specifying a breach of the statutory warranty on the unit and the related limited common elements must be delivered to Declarant before the expiration of such warranty. A written claim reasonably specifying a breach of the statutory warranty on the general common elements must be delivered to Declarant within two years of expiration of such warranty, but the claim must be for a defect existing prior to the expiration of the warranty. An action to enforce the statutory warranty shall not be commenced later than four years after expiration of the warranty.

(2) **Other Claims.** Any other claims under this Section 10.2, including, without limitation allegations of property damage or personal injury claims arising out of fungus, spores, or mold, any water intrusion or dampness, or otherwise, regardless of the legal theory or basis of alleged causation, including but not limited to, negligence, professional errors or omissions, strict liability, breach of contract, or non-statutory warranty, must be commenced under Section 10.2(a) above within ninety (90) days after the date the Association or the unit owner knew or reasonably should have known of facts sufficient to put them on notice of

the claim, **or if earlier**, with respect to the unit and related limited common elements, by no later than the first anniversary of the closing date of the sale of the unit to the first purchaser or, with respect to the general common elements, within ninety (90) days after the date of the Turnover Meeting as described in Section 2.2 of these Bylaws. Any arbitration or litigation based upon such claims must be instituted within ninety (90) days after completion of the mediation proceedings under Section 10.2(b), or if shorter, the applicable statute of limitations. Any and all such claims not brought within these time periods will be deemed time barred, regardless of when the Association or unit owners actually discovered the alleged basis for the claim.

10.3 **Arbitration**. Any arbitration under these Bylaws shall be conducted in the Portland, Oregon metropolitan area, or such other location as may be agreed upon by the parties, pursuant to the arbitration statutes of the State of Oregon and any arbitration award may be enforced by any court with jurisdiction. Filing for arbitration shall be treated the same as filing in court for purposes of meeting any applicable statute of limitations or for purposes of filing a notice of pending action (“lis pendens”).

(a) **Selection of Arbitrator**. The arbitration shall be conducted by a single arbitrator selected by mutual agreement of the parties. The arbitrator selected shall be neutral and unbiased, except to the extent the arbitrator's prior relationship with any party is fully disclosed and consented to by the other party or parties. If the parties are unable to agree upon the arbitrator within thirty (30) days after a party's demand for arbitration, upon application of any party, the Presiding Judge of the Circuit Court of Multnomah County, Oregon shall designate the arbitrator.

(b) **Consolidated Arbitration**. Upon demand by any party, claims between or among the parties and third parties shall be submitted in a single, consolidated arbitration. Notwithstanding the provisions of Section 10.2(c), in the event any claim, controversy or dispute involves a claim by either party against a third party who is not required to and does not voluntarily agree to submit such claim to arbitration, then either party may elect to have the matter determined by a court of law in a consolidated proceeding, rather than by arbitration. In such case, the parties hereby waive trial by jury and agree that the matter shall be determined by a judge sitting without a jury.

(c) **Discovery**. The parties to the arbitration shall be entitled to such discovery as would be available to them in an action in Multnomah County Circuit Court. The arbitrator shall have all of the authority of the Court incidental to such discovery, including without limitation authority to issue orders to produce documents or other materials, to issue orders to appear and submit to deposition, and to impose appropriate sanctions including without limitation award against a party for failure to comply with any order.

(d) **Evidence**. The parties to the arbitration may offer such evidence as they desire and shall produce such additional evidence as the arbitrator may deem necessary for an understanding and determination of the dispute. The arbitrator shall determine the admissibility of the evidence offered. All evidence shall be taken in the presence of the arbitrator and all of the parties, except where any of the parties is absent, in default or has waived its right to be present.

10.4 **Survival.** The mediation and arbitration agreements set forth in this Article 10 shall survive the transfer by any party of its interest or involvement in the Condominium and any unit therein and the termination of the Declaration or these Bylaws.

Article 11

MISCELLANEOUS

11.1 **Notices.** All notices to the Association or to the board of directors shall be sent care of the manager, or if there is no manager, to the principal office of the Association or to such other address as the board of directors may designate from time to time. All notices to any unit owner shall be sent to such address as may have been designated by such owner from time to time, in writing, to the board of directors, or, if no address has been designated, then to the owner's unit.

11.2 **Waiver.** No restriction, condition, obligation, or provision contained in these Bylaws shall be deemed to have been abrogated or waived by reason of any failure to enforce the same, irrespective of the number of violations or breaches thereof which may occur.

11.3 **Action Without a Meeting.** Any action that the Oregon Condominium Act, the Declaration or these Bylaws require or permit the owners or directors to take at a meeting or ballot meeting may be taken without a meeting or ballot meeting if a consent in writing setting forth the action so taken is signed by all of the owners or directors entitled to vote on the matter. The consent, which shall have the same effect as a unanimous vote of the owners or directors, shall be filed in the records of minutes of the Association.

11.4 **Invalidity; Number; Captions.** The invalidity of any part of these Bylaws shall not impair or affect in any manner the validity, enforceability or effect of the balance of these Bylaws. As used in these Bylaws, the singular shall include the plural, and the plural the singular. The masculine and neuter shall each include the masculine, feminine and neuter, as the context requires. All captions are intended solely for convenience of reference and shall in no way limit any of the provisions of these Bylaws.

11.5 **Conflicts.** These Bylaws are intended to comply with the Oregon Condominium Act and the Declaration. In case of any irreconcilable conflict, such statute and document shall control over these Bylaws or any rules and regulations adopted hereunder.

DATED this 28th day of April, 2007.

THE BENSON TOWER, LLC,
an Oregon limited liability company

By: Keith Vernon
Keith Vernon, Authorized Signer